



# Paola City Council Meeting - AGENDA

Tuesday, December 13, 2022 - 6:00 PM

Paola Justice Center - 805 N PEARL

YouTube Channel: [https://www.youtube.com/channel/UCElgDJjzXV\\_XvXznUfKQomw?](https://www.youtube.com/channel/UCElgDJjzXV_XvXznUfKQomw?)

## PLEDGE OF ALLEGIANCE

## CALL TO ORDER

ROLL CALL - Smail \_\_\_ Hayes \_\_\_ Peckman \_\_\_ Shields \_\_\_ Mayor House \_\_\_

### 1. CONSENT AGENDA

The items on the Consent Agenda are considered by the Governing Body to be routine business items. Agenda items may be approved by a single motion, second and a majority vote with no separate discussion of any item listed. Should a member of the Governing Body desire to discuss any item, at his/her request it will be removed from the Consent Agenda and considered separately.

- a. Meeting Minutes – November 8, 2022.
- b. Salary Ordinances - 22-23, 22-24, 22-25 & 22-26
- c. Appropriation Ordinances -987 & 988
- d. Pledged Collateral Report – November 2022
- e. Journal Entries Report - November 2022
- f. Renewal of a liquor license for Papa C's, 807 S Silver, contingent upon receipt of application and fee.
- g. Approval of the renewal of Cereal Malt Beverage Licenses for 2023 contingent upon return of application and fee and completed safety inspection:
  - Price Chopper at 309 N Hospital Drive – Off Premises
  - Casey's General Store #1237 at 119 N Hospital Drive – Off Premises
  - Casey's General Store #1337 at 404 S Silver Street – Off Premises
  - Milo's Steak House at 16 W Peoria Street – On Premises
  - Walmart at 310 Hedge Lane – Off Premises
  - Fuel Espresso #15 at 1005 N Pearl Street – Off Premises
  - Pizza Hut at 1613 E Peoria – On Premises
  - One Stop Convenience - Off Premises
- h. Leak allowance for Kim Coons at 405 W Wea for \$506.76

Possible Action - Motion to approve the Consent Agenda as presented and authorize the Mayor to sign.

Motion: \_\_\_\_\_ Second: \_\_\_\_\_ Vote: \_\_\_\_\_

**2. COMMENTS FROM THE PUBLIC**

When addressing the Council, please step to the podium and state your name and address so that it can be recorded in the minutes of the meeting. Please limit your comments to 3 minutes or less and to items NOT on the agenda. Thank you.

**3. ELECTION RESULTS**

**a. Consider Certificate of Election Results**

Possible Action - Motion to accept the certificate of election results naming Trent Upshaw - City Council Ward 2 and LeAnne Shields - City Council Ward 4 as the candidates receiving the most votes.

Motion: \_\_\_\_\_ Second: \_\_\_\_\_ Vote: \_\_\_\_\_

**b. Council Election to fill Ward 2 Council Seat**

Possible Action - Motion to nominate \_\_\_\_\_ to fill the position of Ward 2 City Council member.

Motion: \_\_\_\_\_ Second: \_\_\_\_\_ Vote: \_\_\_\_\_

**4. RECESS SINE DIE - Installation of newly elected City Council**

Possible Action - Motion to recess sine die (*Latin: "without day"*)

Motion: \_\_\_\_\_ Second: \_\_\_\_\_ Vote: \_\_\_\_\_

**5. ADMINISTRATION OF OATH OF OFFICE**

a. Council Members - \_\_\_\_\_ - Ward 2 & LeAnne Shields - Ward 4

**6. INVOCATION**

**7. RESUME COUNCIL MEETING**

Possible Action - Motion to resume the recessed meeting.

Motion: \_\_\_\_\_ Second: \_\_\_\_\_ Vote: \_\_\_\_\_

**8. ELECTION OF COUNCIL OFFICERS**

Possible Action - Motion to nominate Council Member \_\_\_\_\_ as President of the Paola City Council

Motion: \_\_\_\_\_ Second: \_\_\_\_\_ Vote: \_\_\_\_\_

Possible Action - Motion to nominate Council member \_\_\_\_\_ as Vice President of the Paola City Council.

Motion: \_\_\_\_\_ Second: \_\_\_\_\_ Vote: \_\_\_\_\_

**9. NEW BUSINESS**

**a. Landworks Studio Contract**

Possible Action - Motion to approve the contract from Landworks Studio in the form substantially presented and authorize the necessary signatures.

Motion: \_\_\_\_\_ Second: \_\_\_\_\_ Vote: \_\_\_\_\_

**b. Hedge Ln. & Baptiste Dr. Traffic Light & Cabinet Upgrade**

Possible Action - Motion to approve the quote from J. Warren Company Inc. for improvements to the traffic lights and control cabinet at Hedge Ln. & Baptiste Dr. in the amount of \$39,744.00.

Motion: \_\_\_\_\_ Second: \_\_\_\_\_ Vote: \_\_\_\_\_

**c. Fire Engine Purchase Approval**

Possible Action - Motion to approve the purchasing of a Sutphen Monarch S1, from the Sutphen Corporation in the amount of \$606,537.85.

Motion: \_\_\_\_\_ Second: \_\_\_\_\_ Vote: \_\_\_\_\_

**d. Traffic Control Device Schedule - Resolution 2022-011 - Parking Restriction by the Miami County Administration Building.**

Possible Action - Motion to approve Resolution 2022-011 amending the official Traffic Control Device Schedule.

Motion: \_\_\_\_\_ Second: \_\_\_\_\_ Vote: \_\_\_\_\_

**e. Approval of an Employment Agreement.**

Possible Action - Motion to approve an Employment Agreement with Randi Shannon to serve as City Manager for the City of Paola and authorize the necessary signatures.

Motion: \_\_\_\_\_ Second: \_\_\_\_\_ Vote: \_\_\_\_\_

**10. STAFF REPORTS**

**11. MISCELLANEOUS MATTERS FROM THE COUNCIL**

**12. MISCELLANEOUS MATTERS FROM THE MAYOR**

**13. EXECUTIVE SESSION**

*Possible Action - I move city council recess into Executive Session for the preliminary discussion of the acquisition of real property, pursuant to exception, K.S.A. 75-4319(b)(6). The meeting shall include the Mayor and Council, City Manager, and City Clerk,. The regular meeting shall reconvene in the Municipal Court Room at [state actual time].*

Motion: \_\_\_\_\_ Second: \_\_\_\_\_ Vote: \_\_\_\_\_

Possible Action - Motion to reconvene the recessed meeting

Motion: \_\_\_\_\_ Second: \_\_\_\_\_ Vote: \_\_\_\_\_

## 14. ADJOURNMENT

Possible Action – Motion to adjourn.

Motion: \_\_\_\_\_ Second: \_\_\_\_\_ Vote: \_\_\_\_\_

**~ NOTICE ~**

In compliance with the American with Disabilities Act, individuals needing assistance or other services or accommodation for this meeting should contact City Clerk Stephanie Marler at least 24 hours in advance of this meeting at 913-259-3600.

**MINUTES OF THE COUNCIL MEETING  
OF THE CITY OF PAOLA, KANSAS  
PAOLA JUSTICE CENTER 805 N PEARL  
6:00 O’CLOCK P.M.  
November 8, 2022**

The Governing Body of the City of Paola, Kansas, met with Mayor House presiding.

**Council Members present:** Mayor Leigh House and Council Members Dave Smail, Deborah Hayes, Kathy Peckman and LeAnne Shields.

**Council Members absent:** None

**Also present:** City Manager Randi Shannon, City Clerk Stephanie Marler, Police Chief Eric Jenkins, Public Works Director Kirk Rees, City Planner Jessica Newton, HR Director Vicki Belt, City Attorney Lee Tetwiler, Brian McCauley with the Miami County Republic, Trent Upshaw, Steve Cowman, Pete Bell, Nathan Lippert, John McLean, Timothy Kitchens, Gary Hink, Kirk Davis, Jay Wieland, Scott Golubski and others.

**CALL TO ORDER:** The regular council meeting was called to order by Mayor House.

**ROLL CALL:** Mayor House and Council Members Smail, Hayes, Peckman and Shields were all present.

**Agenda Item 1 - CONSENT AGENDA**

- a. Approval of minutes of the meeting of October 11, 2022.
- b. Approval of Salary Ordinances 22-21 & 22-22.
- c. Approval of Appropriation Ordinance 985 & 986.
- d. Approval of the Pledged Collateral Report for October 2022.
- e. Approval of Journal Entries report for October 2022
- f. Renewal of a private club license for VFW, 202 Delaware, contingent on receipt of application.

Council Member Smail made a motion to approve the Consent Agenda as presented and authorize the mayor to sign. The motion was seconded by Council Member Peckman and all voted aye. The motion passed 4 to 0.

**Agenda Item 2 - COMMENTS FROM THE PUBLIC:**

No comments for non-agenda items.

**Agenda Item 3 – OLD BUSINESS**

**Agenda Item 3a – 2018 Fire Code Adoption**

Council Member Peckman made a motion to adopt Ordinance No 3195 incorporating by reference the 2018 Edition of the International Fire Code. The motion was seconded by Council Member Hayes and all voted aye. The motion passed 4 to 0.

**Agenda Item 3b – 2018 Building Code Adoption**

Council Member Shields made a motion to adopt Ordinance No 3196 incorporating by reference the 2018 Edition of the International Building Code. The motion was seconded by Council Member Smail and all voted aye. The motion passed 4 to 0.

**Agenda Item 4 – NEW BUSINESS**

**Agenda Item 4e was moved to the beginning of the agenda due to public comment on the item.**

**Agenda Item 4e – Consideration of Wallace Park Ballfield Final Site Plan**

Mayor House reminded the audience this discussion is for the ballfield final site plan since the project has already been approved. She asked if anyone in the audience would like to make a comment.

Jay Wieland, 221 Brookside Dr, wanted to address a letter to the editor regarding the Legion transfer of land for the ballfields. He stated there were some items in the letter that needed to be clarified. Mr. Wieland said the City did not approach the Legion on the transfer of the property but rather the Legion and Paola Baseball and Softball Association approached the City. Mr. Wieland also said he spent time with Legion members Mr. Pete Bell and Mr. John McLean to discuss how an agreement could be made due to concerns with the Russell Quit Claim deed, noting the issue with the deed is why it took so long to complete. He also said there was never intention for the City to own the land under the Legion building and when the agreement was written that was the understanding for both parties.

Pete Bell, 209 N Castle, introduced himself as the Finance Officer for the Legion and author of the letter to the editor. He said the Legion and Baseball Association did approach the City because the Legion could no longer afford Legion ball. He agreed the City would have never intended to take the ground under the building, the problem is they have. Mr. Bell believes the City has acknowledged they took the land by offering a new deed to give it back. His concern is the site plan for the new fields will not fit on the land that was intended to be given. Mr. Bell said the commander, who was falsely convinced to sign the agreement, has passed away and the members were unaware of what was written until 2 months ago. He said he is upset because he was assured the land issue would be taken care of before a contract (with Mammoth) was signed and that was not the case. He then said he was told if the Legion has a problem to get a lawyer. He then thanked Mr. Wieland for coming forward about this issue.

Scott Golubski, 33105 Harmony Rd, said during the timeline of the land transfer he was the president of Paola Youth Baseball and on the Legion Youth Baseball board. He said he was

involved in the request to the City to accept the donated land from the Legion. His conversations were with Mr. Mike Welter and Mr. John McLean and he had also attended a meeting with the Legion members regarding the land transfer. He then said he knows everyone will not be happy but appreciates everything that has been done for the benefit of the youth and the businesses in the City.

Planner Newton said the Planning Commission voted 4 to 2 at their October 18, 2022 meeting to recommend approval of the final site plan submitted by Mammoth Sports Construction for the construction of two new synthetic turf fields in Wallace Park with the following conditions:

1. Resolution of gas line issues
2. Satisfy any concerns with the public parking coordination between the Legion and recreational activities.

She said the total area for this project is 4.06 acres, which includes the extension of the existing gravel parking lot on the north side of the fields. She said the Planning Commission asked about hard surface handicap parking and Mammoth supplied 3 options to provide that.

Planner Newton said the site plan was completed by CEI Engineering Associates, Inc. and reviewed by Wilson & Co. Mammoth has submitted the required Notice of Intent and Storm Water Pollution Prevention Plan to the State of Kansas. She noted the City has been in contact with Kansas Gas Company regarding the gas line that runs under the west field. With the existing Franchise Agreement, should the line need to be rerouted that will be at the expense of the gas company. She said the gas line lies four feet underground and the excavation is only eighteen inches.

Council Member Peckman asked Mr. Steve Cowman, Chairman of the Planning Commission, if he would like to reiterate anything that was discussed. He said Planner Newton covered it.

Council Member Shields said she went to the Planning Commission meeting and believed the intent for the recommendation by the commission was to make sure the finalization of the Legion Legal Agreement was done before moving forward with the project. Manager Shannon said the parking issue in the current agreement was the concern and directed any legal concerns about an agreement to Attorney Tetwiler.

Attorney Tetwiler said there is an agreement dated December 2, 2019 and a deed that are already in place. He did admonish the Council stating they should be cautious about breaching a two-million-dollar contract that has already been approved. He suggested to call the question and vote to discourage legal matters being discussed in the public meeting.

Council Member Smail made a motion to approve the site plan submitted by Mammoth Sports Construction for the construction of two new synthetic turf fields in Wallace Park. The motion was seconded by Council Member Hayes. Council Members Smail, Hayes and Peckman all voted aye. Council Member Shields voted nay.



**Agenda Item 4a – 2023 Group Health Insurance Renewal**

HR Director Belt addressed the Council stating an increase of 75% for health insurance was expected due to three large claims over \$25,000. The broker suggested bidding out the insurance but when two companies saw the City's numbers they declined and another came in at 40%. Blue Cross and Blue Shield reevaluated and offered an increase of 19%. Delta Dental has an increase of less than 2% and Surency and Met Life were minimal.

HR Director Belt noted there were no changes in the plan and this is the same plan employees have had for several years.

With no further comment Council Member Smail made a motion to approve the renewal of the City's current group insurance plans with Blue Cross and Blue Shield, Delta Dental, Surency and MetLife as presented. The motion was seconded by Council Member Peckman and all voted aye. The motion passed 4 to 0.

**Agenda Item 4b – Consider Employee Christmas Gifts**

HR Director Belt explained she spoke with the City's auditor about running the Christmas gift amount through payroll without taking State or Federal tax out of the gift amount. She said eventually the taxes will be paid by the employee at tax time but they will receive more of the gift before Christmas.

Council Member Peckman made a motion to approve the processing of \$200 through payroll as a Christmas gift to City Employees. The motion was seconded by Council Member Hayes and all voted aye. The motion passed 4 to 0.

**Agenda Item 4c – New CMB license for One Stop Convenience.**

Clerk Marler said a convenience store is opening at 604 N Silver called One Stop Convenience. The owner, Mr. Jawaad Arif, has submitted the proper applications and fee. She said Mr. Arif believes the store will be open before January 1 so he is applying for a license that will expire December 31, 2022.

Clerk Marler said the location is still under construction so it is not possible to complete the safety inspection. Mr. Arif would not receive his license until the inspection is passed.

Council Member Shields made a motion to approve a new Cereal Malt Beverage license for One Stop Convenience, LLC at 604 N Silver contingent upon a passed safety inspection. The motion was seconded by Council Member Peckman and all voted aye. The motion passed 4 to 0.

**Agenda Item 4d – Consideration of Lakemary Campus Final Site Plan**

Planner Newton said at the August 16, 2022 Planning Commission meeting they reviewed the request for site plan approval for a new dormitory and existing building renovation on the Lakemary campus. She said the new 17,000 square foot dormitory will house forty residents, combining two existing residential units onsite. She said access to the new dormitory building

will be through a newly installed sidewalk system. There will be a fire access lane installed along the eastern edge of the property.

She said the Planning Commission voted unanimously to recommend approval of the plan with the following conditions:

1. Applicant satisfies engineering comments in reference to the drainage plan.
  - a. *Final review with approval from Wilson & Company was received by Staff 09/25/2022*
2. Applicant performs a drainage plan/study for the west portion.
  - a. *West side drainage study was submitted to Wilson & Company. Initial comments were received and forwarded to Hoefler-Welker on 10/27/2022*

Council Member Peckman made a motion to approve the site plan for Lakemary campus with the condition that the applicant satisfies Wilson & Co. engineering comments from August 10, 2022 and satisfy the Planning Commission condition to complete a drainage study of the west side of Lakemary campus. The motion was seconded by Council Member Shields and all voted aye. The motion passed 4 to 0.

**Agenda Item 5 – COMMITTEE REPORTS – None**

**Agenda Item 6 - STAFF REPORTS**

Chief Jenkins said the Police Department is working on planning for Shop with a Cop which is a grant provided through Walmart.

Clerk Marler said since it is Election Day there is no report on election results. She did note should Trent Upshaw win the election, being the only name for Ward 2 on the ballot, the seat will be open and the public will be asked to submit letters if they are interested in filling it.

Planner Newton said the Planning Commission will meet next week and the site plan for Taylor Forge will be on the agenda.

**Agenda Item 8 - MISCELLANEOUS MATTERS FROM THE COUNCIL:**

Council Member Peckman said she had some concerns about the budget numbers. She said the administration fund should be watched closely.

**Agenda Item 9 - MISCELLANEOUS MATTERS FROM THE MAYOR:**

Mayor House thanked Council and Staff for working through the challenges lately.

**Agenda Item 10 – EXECUTIVE SESSION**

Council Member Smail moved city council recess into executive session to discuss the evaluation and contract for the City Manager pursuant to the non-elected personnel matter exception, K.S.A. 75-4319(b)(1). The meeting shall include the Mayor and Council, City Attorney and City Manager. The regular meeting shall reconvene in the Municipal Court Room at 7:10 PM. The motion was seconded by Council Member Hayes and all voted aye. The motion passed 4 to 0.

At 7:10 PM Council came out of executive session. Council Member Smail made a motion to reconvene the recessed meeting. The motion was seconded by Council Member Hayes and all voted aye. The motion passed 4 to 0.

**Agenda Item 11– ADJOURNMENT**

With no additional business to come before the Council, Council Member Smail made a motion to adjourn. The motion was seconded by Council Member Hayes and all voted aye. The motion passed 4 to 0.

---

Leigh House, Mayor

ATTEST: [seal]

---

Stephanie Marler, City Clerk

## Costs by GL Number Report

SAL ORD 22-23 CITY 11/16/22

Emp.Code Desc.: CITY OF PAOLA, KANSAS

City of Paola

Pay Ending Date: 11/5/2022

Pay Date: 11/16/2022

Date: 11/8/2022

Time: 11:52:49

GL Number	Gross Pay	KP&F 22.99	Medicare	RET 1%	RET 8.9%	RET CITY	RET WRL	Soc Sec	Other
01-001-700.100	\$15,524.60	\$0.00	\$213.78	\$154.50	\$1,375.01	\$0.00	\$0.00	\$914.10	\$2,026.89
01-001-700.110	\$571.32	\$0.00	\$8.28	\$5.71	\$50.85	\$0.00	\$0.00	\$35.42	\$24.68
01-001-700.130	\$318.47	\$0.00	\$5.62	\$0.00	\$0.00	\$0.00	\$0.00	\$24.07	\$70.71
01-002-700.100	\$35,393.12	\$6,403.05	\$495.21	\$75.42	\$671.20	\$0.00	\$0.00	\$2,117.39	\$3,717.87
01-002-700.110	\$216.48	\$0.00	\$3.14	\$0.00	\$0.00	\$0.00	\$0.00	\$13.42	\$9.36
01-002-700.120	\$5,161.61	\$1,111.48	\$72.27	\$3.27	\$29.10	\$0.00	\$0.00	\$309.05	\$543.67
01-002-700.272	\$200.00	\$45.98	\$2.83	\$0.00	\$0.00	\$0.00	\$0.00	\$12.07	\$20.56
01-003-700.100	\$11,546.18	\$0.00	\$167.43	\$0.00	\$0.00	\$0.00	\$0.00	\$715.86	\$790.99
01-004-700.100	\$1,668.80	\$0.00	\$23.49	\$16.69	\$148.52	\$0.00	\$0.00	\$100.42	\$181.01
01-004-700.110	\$1,399.74	\$0.00	\$20.30	\$0.00	\$0.00	\$0.00	\$0.00	\$86.78	\$4.48
01-005-700.100	\$13,932.80	\$0.00	\$192.76	\$139.33	\$1,240.02	\$0.00	\$0.00	\$824.21	\$2,415.63
01-006-700.100	\$7,375.30	\$0.00	\$96.14	\$73.77	\$656.39	\$0.00	\$0.00	\$411.09	\$1,837.43
01-006-700.110	\$389.50	\$0.00	\$5.65	\$0.00	\$0.00	\$0.00	\$0.00	\$24.15	\$12.27
01-009-700.100	\$5,794.40	\$0.00	\$81.04	\$57.94	\$515.70	\$0.00	\$0.00	\$346.53	\$744.27
<b>Totals for Fund 01</b>	<b>\$99,492.32</b>	<b>\$7,560.51</b>	<b>\$1,387.94</b>	<b>\$526.63</b>	<b>\$4,686.79</b>	<b>\$0.00</b>	<b>\$0.00</b>	<b>\$5,934.56</b>	<b>\$12,399.82</b>
GL Number	Gross Pay	KP&F 22.99	Medicare	RET 1%	RET 8.9%	RET CITY	RET WRL	Soc Sec	Other
02-022-700.100	\$4,539.86	\$0.00	\$63.66	\$45.39	\$404.04	\$0.00	\$0.00	\$272.20	\$643.46
02-022-700.110	\$1,437.86	\$0.00	\$20.85	\$12.42	\$110.53	\$0.00	\$0.00	\$89.15	\$12.44
02-022-700.111	\$896.43	\$0.00	\$13.00	\$0.00	\$0.00	\$0.00	\$0.00	\$55.58	\$2.86
02-022-700.120	\$8.65	\$0.00	\$0.11	\$0.09	\$0.77	\$0.00	\$0.00	\$0.48	\$1.63
<b>Totals for Fund 02</b>	<b>\$6,882.80</b>	<b>\$0.00</b>	<b>\$97.62</b>	<b>\$57.90</b>	<b>\$515.34</b>	<b>\$0.00</b>	<b>\$0.00</b>	<b>\$417.41</b>	<b>\$660.39</b>

## Costs by GL Number Report

SAL ORD 22-23 CITY 11/16/22

Emp.Code Desc.: CITY OF PAOLA, KANSAS

City of Paola

Pay Ending Date: 11/5/2022

Pay Date: 11/16/2022

Date: 11/8/2022

Time: 11:52:49

GL Number	Gross Pay	KP&F 22.99	Medicare	RET 1%	RET 8.9%	RET CITY	RET WRL	Soc Sec	Other
04-032-700.100	\$2,221.60	\$0.00	\$32.06	\$22.22	\$197.72	\$0.00	\$0.00	\$137.07	\$253.05
04-032-700.120	\$83.31	\$0.00	\$1.20	\$0.83	\$7.42	\$0.00	\$0.00	\$5.14	\$8.76
04-033-700.100	\$4,981.92	\$0.00	\$67.41	\$49.82	\$443.38	\$0.00	\$0.00	\$288.20	\$1,035.78
04-033-700.120	\$393.31	\$0.00	\$5.31	\$3.93	\$35.01	\$0.00	\$0.00	\$22.72	\$71.69
<b>Totals for Fund 04</b>	<b>\$7,680.14</b>	<b>\$0.00</b>	<b>\$105.98</b>	<b>\$76.80</b>	<b>\$683.53</b>	<b>\$0.00</b>	<b>\$0.00</b>	<b>\$453.13</b>	<b>\$1,369.28</b>
GL Number	Gross Pay	KP&F 22.99	Medicare	RET 1%	RET 8.9%	RET CITY	RET WRL	Soc Sec	Other
08-000-700.100	\$2,459.60	\$0.00	\$35.24	\$24.10	\$214.45	\$0.00	\$0.00	\$150.66	\$218.83
08-000-700.110	\$238.00	\$0.00	\$3.45	\$0.00	\$0.00	\$0.00	\$0.00	\$14.76	\$10.28
<b>Totals for Fund 08</b>	<b>\$2,697.60</b>	<b>\$0.00</b>	<b>\$38.69</b>	<b>\$24.10</b>	<b>\$214.45</b>	<b>\$0.00</b>	<b>\$0.00</b>	<b>\$165.42</b>	<b>\$229.11</b>
GL Number	Gross Pay	KP&F 22.99	Medicare	RET 1%	RET 8.9%	RET CITY	RET WRL	Soc Sec	Other
09-033-700.100	\$1,407.20	\$0.00	\$20.41	\$14.07	\$125.24	\$0.00	\$0.00	\$87.24	\$62.35
09-033-700.120	\$39.58	\$0.00	\$0.57	\$0.40	\$3.52	\$0.00	\$0.00	\$2.46	\$1.18
<b>Totals for Fund 09</b>	<b>\$1,446.78</b>	<b>\$0.00</b>	<b>\$20.98</b>	<b>\$14.47</b>	<b>\$128.76</b>	<b>\$0.00</b>	<b>\$0.00</b>	<b>\$89.70</b>	<b>\$63.53</b>
<b>Grand Totals</b>	<b>\$118,199.64</b>	<b>\$7,560.51</b>	<b>\$1,651.21</b>	<b>\$699.90</b>	<b>\$6,228.87</b>	<b>\$0.00</b>	<b>\$0.00</b>	<b>\$7,060.22</b>	<b>\$14,722.13</b>

**SEAL: Stephanie D. Marler, City Clerk**

**Leigh House, Mayor**

## Costs by GL Number Report

SAL ORD 22-24 CITY 11/30/22

Emp.Code Desc.: CITY OF PAOLA, KANSAS

City of Paola

Pay Ending Date: 11/19/2022

Pay Date: 11/30/2022

Date: 11/22/2022

Time: 9:09:44

GL Number	Gross Pay	KP&F 22.99	Medicare	RETM 1%	RETM 8.9%	RET CITY	RETWRL	Soc Sec	Other
01-001-700.100	\$15,449.60	\$0.00	\$224.02	\$154.50	\$1,375.01	\$0.00	\$0.00	\$957.87	\$121.77
01-001-700.110	\$603.06	\$0.00	\$8.74	\$6.03	\$53.67	\$0.00	\$0.00	\$37.39	\$26.05
01-001-700.130	\$318.47	\$0.00	\$4.60	\$0.00	\$0.00	\$0.00	\$0.00	\$19.73	\$0.71
01-002-700.100	\$35,407.55	\$6,474.58	\$513.40	\$72.45	\$644.81	\$0.00	\$0.00	\$2,195.29	\$935.64
01-002-700.110	\$236.77	\$0.00	\$3.43	\$0.00	\$0.00	\$0.00	\$0.00	\$14.68	\$10.23
01-002-700.120	\$4,751.41	\$1,010.94	\$68.88	\$3.54	\$31.52	\$0.00	\$0.00	\$294.59	\$97.32
01-002-700.121	\$3,739.19	\$710.48	\$54.24	\$6.49	\$57.73	\$0.00	\$0.00	\$231.81	\$72.71
01-002-700.272	\$100.00	\$22.99	\$1.45	\$0.00	\$0.00	\$0.00	\$0.00	\$6.20	\$3.24
01-003-700.100	\$8,968.68	\$0.00	\$130.07	\$0.00	\$0.00	\$0.00	\$0.00	\$556.06	\$609.68
01-004-700.100	\$1,668.80	\$0.00	\$24.20	\$16.69	\$148.52	\$0.00	\$0.00	\$103.47	\$5.34
01-004-700.110	\$1,399.74	\$0.00	\$20.30	\$0.00	\$0.00	\$0.00	\$0.00	\$86.78	\$4.48
01-005-700.100	\$13,408.80	\$0.00	\$194.42	\$134.09	\$1,193.39	\$0.00	\$0.00	\$831.35	\$717.21
01-006-700.100	\$7,683.52	\$0.00	\$111.41	\$76.84	\$683.82	\$0.00	\$0.00	\$476.39	\$239.48
01-006-700.110	\$389.50	\$0.00	\$5.65	\$0.00	\$0.00	\$0.00	\$0.00	\$24.15	\$12.27
01-009-700.100	\$5,794.40	\$0.00	\$84.02	\$57.94	\$515.70	\$0.00	\$0.00	\$359.25	\$178.21
<b>Totals for Fund 01</b>	<b>\$99,919.49</b>	<b>\$8,218.99</b>	<b>\$1,448.83</b>	<b>\$528.57</b>	<b>\$4,704.17</b>	<b>\$0.00</b>	<b>\$0.00</b>	<b>\$6,195.01</b>	<b>\$3,034.34</b>
GL Number	Gross Pay	KP&F 22.99	Medicare	RETM 1%	RETM 8.9%	RET CITY	RETWRL	Soc Sec	Other
02-022-700.100	\$4,515.78	\$0.00	\$65.48	\$45.16	\$401.90	\$0.00	\$0.00	\$279.98	\$14.44
02-022-700.110	\$1,620.50	\$0.00	\$23.50	\$14.31	\$127.40	\$0.00	\$0.00	\$100.48	\$12.75
02-022-700.111	\$1,219.29	\$0.00	\$17.68	\$0.00	\$0.00	\$0.00	\$0.00	\$75.60	\$3.92
<b>Totals for Fund 02</b>	<b>\$7,355.57</b>	<b>\$0.00</b>	<b>\$106.66</b>	<b>\$59.47</b>	<b>\$529.30</b>	<b>\$0.00</b>	<b>\$0.00</b>	<b>\$456.06</b>	<b>\$31.11</b>

## Costs by GL Number Report

SAL ORD 22-24 CITY 11/30/22

Emp.Code Desc.: CITY OF PAOLA, KANSAS

City of Paola

Pay Ending Date: 11/19/2022

Pay Date: 11/30/2022

Date: 11/22/2022

Time: 9:09:44

GL Number	Gross Pay	KP&F 22.99	Medicare	RETM 1%	RETM 8.9%	RET CITY	RETWRL	Soc Sec	Other
04-032-700.100	\$2,450.70	\$0.00	\$35.54	\$24.51	\$218.11	\$0.00	\$0.00	\$151.94	\$64.42
04-033-700.100	\$5,021.52	\$0.00	\$72.81	\$50.21	\$446.92	\$0.00	\$0.00	\$311.33	\$231.50
<b>Totals for Fund 04</b>	<b>\$7,472.22</b>	<b>\$0.00</b>	<b>\$108.35</b>	<b>\$74.72</b>	<b>\$665.03</b>	<b>\$0.00</b>	<b>\$0.00</b>	<b>\$463.27</b>	<b>\$295.92</b>
GL Number	Gross Pay	KP&F 22.99	Medicare	RETM 1%	RETM 8.9%	RET CITY	RETWRL	Soc Sec	Other
08-000-700.100	\$2,409.60	\$0.00	\$34.94	\$24.10	\$214.45	\$0.00	\$0.00	\$149.40	\$7.71
08-000-700.110	\$189.00	\$0.00	\$2.74	\$0.00	\$0.00	\$0.00	\$0.00	\$11.72	\$8.17
<b>Totals for Fund 08</b>	<b>\$2,598.60</b>	<b>\$0.00</b>	<b>\$37.68</b>	<b>\$24.10</b>	<b>\$214.45</b>	<b>\$0.00</b>	<b>\$0.00</b>	<b>\$161.12</b>	<b>\$15.88</b>
GL Number	Gross Pay	KP&F 22.99	Medicare	RETM 1%	RETM 8.9%	RET CITY	RETWRL	Soc Sec	Other
09-033-700.100	\$1,415.99	\$0.00	\$20.53	\$14.16	\$126.02	\$0.00	\$0.00	\$87.79	\$62.73
<b>Totals for Fund 09</b>	<b>\$1,415.99</b>	<b>\$0.00</b>	<b>\$20.53</b>	<b>\$14.16</b>	<b>\$126.02</b>	<b>\$0.00</b>	<b>\$0.00</b>	<b>\$87.79</b>	<b>\$62.73</b>
<b>Grand Totals</b>	<b>\$118,761.87</b>	<b>\$8,218.99</b>	<b>\$1,722.05</b>	<b>\$701.02</b>	<b>\$6,238.97</b>	<b>\$0.00</b>	<b>\$0.00</b>	<b>\$7,363.25</b>	<b>\$3,439.98</b>

**SEAL: Stephanie D. Marler, City Clerk**

**Leigh House, Mayor**

## Costs by GL Number Report

Sal Ord 22-25 Holiday 12/08/22

Emp.Code Desc.: CITY OF PAOLA, KANSAS

City of Paola

Pay Ending Date: 12/8/2022

Pay Date: 12/8/2022

Date: 12/1/2022

Time: 9:49:26

GL Number	Gross Pay	KP&F 22.99	Medicare	RETM 1%	RETM 8.9%	RET CITY	RETWRL	Soc Sec	Other
01-001-700.100	\$1,200.00	\$0.00	\$17.40	\$12.00	\$106.80	\$0.00	\$0.00	\$74.40	\$0.00
01-001-700.110	\$200.00	\$0.00	\$2.90	\$2.00	\$17.80	\$0.00	\$0.00	\$12.40	\$0.00
01-001-700.130	\$1,000.00	\$0.00	\$14.50	\$0.00	\$0.00	\$0.00	\$0.00	\$62.00	\$0.00
01-002-700.100	\$3,200.00	\$597.74	\$46.40	\$6.00	\$53.40	\$0.00	\$0.00	\$198.40	\$0.00
01-002-700.110	\$200.00	\$0.00	\$2.90	\$0.00	\$0.00	\$0.00	\$0.00	\$12.40	\$0.00
01-003-700.100	\$6,600.00	\$0.00	\$95.70	\$0.00	\$0.00	\$0.00	\$0.00	\$409.20	\$0.00
01-004-700.100	\$200.00	\$0.00	\$2.90	\$2.00	\$17.80	\$0.00	\$0.00	\$12.40	\$0.00
01-004-700.110	\$200.00	\$0.00	\$2.90	\$0.00	\$0.00	\$0.00	\$0.00	\$12.40	\$0.00
01-005-700.100	\$1,200.00	\$0.00	\$17.40	\$12.00	\$106.80	\$0.00	\$0.00	\$74.40	\$0.00
01-006-700.100	\$800.00	\$0.00	\$11.60	\$8.00	\$71.20	\$0.00	\$0.00	\$49.60	\$0.00
01-009-700.100	\$600.00	\$0.00	\$8.70	\$6.00	\$53.40	\$0.00	\$0.00	\$37.20	\$0.00
<b>Totals for Fund 01</b>	<b>\$15,400.00</b>	<b>\$597.74</b>	<b>\$223.30</b>	<b>\$48.00</b>	<b>\$427.20</b>	<b>\$0.00</b>	<b>\$0.00</b>	<b>\$954.80</b>	<b>\$0.00</b>
GL Number	Gross Pay	KP&F 22.99	Medicare	RETM 1%	RETM 8.9%	RET CITY	RETWRL	Soc Sec	Other
02-022-700.100	\$600.00	\$0.00	\$8.70	\$6.00	\$53.40	\$0.00	\$0.00	\$37.20	\$0.00
02-022-700.110	\$600.00	\$0.00	\$8.70	\$4.00	\$35.60	\$0.00	\$0.00	\$37.20	\$0.00
02-022-700.111	\$800.00	\$0.00	\$11.60	\$0.00	\$0.00	\$0.00	\$0.00	\$49.60	\$0.00
<b>Totals for Fund 02</b>	<b>\$2,000.00</b>	<b>\$0.00</b>	<b>\$29.00</b>	<b>\$10.00</b>	<b>\$89.00</b>	<b>\$0.00</b>	<b>\$0.00</b>	<b>\$124.00</b>	<b>\$0.00</b>
GL Number	Gross Pay	KP&F 22.99	Medicare	RETM 1%	RETM 8.9%	RET CITY	RETWRL	Soc Sec	Other
04-032-700.100	\$200.00	\$0.00	\$2.90	\$2.00	\$17.80	\$0.00	\$0.00	\$12.40	\$0.00
04-033-700.100	\$600.00	\$0.00	\$8.70	\$6.00	\$53.40	\$0.00	\$0.00	\$37.20	\$0.00
<b>Totals for Fund 04</b>	<b>\$800.00</b>	<b>\$0.00</b>	<b>\$11.60</b>	<b>\$8.00</b>	<b>\$71.20</b>	<b>\$0.00</b>	<b>\$0.00</b>	<b>\$49.60</b>	<b>\$0.00</b>



## Costs by GL Number Report

Sal Ord 22-25 Holiday 12/08/22

Emp.Code Desc.: CITY OF PAOLA, KANSAS

City of Paola

Pay Ending Date: 12/8/2022

Pay Date: 12/8/2022

Date: 12/1/2022

Time: 9:49:26

GL Number	Gross Pay	KP&F 22.99	Medicare	RETM 1%	RETM 8.9%	RET CITY	RETWRL	Soc Sec	Other
07-000-700.110	\$200.00	\$0.00	\$2.90	\$0.00	\$0.00	\$0.00	\$0.00	\$12.40	\$0.00
<b>Totals for Fund 07</b>		\$200.00	\$0.00	\$2.90	\$0.00	\$0.00	\$0.00	\$12.40	\$0.00
GL Number	Gross Pay	KP&F 22.99	Medicare	RETM 1%	RETM 8.9%	RET CITY	RETWRL	Soc Sec	Other
08-000-700.100	\$200.00	\$0.00	\$2.90	\$2.00	\$17.80	\$0.00	\$0.00	\$12.40	\$0.00
08-000-700.110	\$200.00	\$0.00	\$2.90	\$0.00	\$0.00	\$0.00	\$0.00	\$12.40	\$0.00
<b>Totals for Fund 08</b>		\$400.00	\$0.00	\$5.80	\$2.00	\$17.80	\$0.00	\$24.80	\$0.00
GL Number	Gross Pay	KP&F 22.99	Medicare	RETM 1%	RETM 8.9%	RET CITY	RETWRL	Soc Sec	Other
09-033-700.100	\$200.00	\$0.00	\$2.90	\$2.00	\$17.80	\$0.00	\$0.00	\$12.40	\$0.00
<b>Totals for Fund 09</b>		\$200.00	\$0.00	\$2.90	\$2.00	\$17.80	\$0.00	\$12.40	\$0.00
<b>Grand Totals</b>		\$19,000.00	\$597.74	\$275.50	\$70.00	\$623.00	\$0.00	\$1,178.00	\$0.00

**SEAL: Stephanie D. Marler, City Clerk**

**Leigh House, Mayor**

## Costs by GL Number Report

Sal Ord 22-26 CITY 12/14/22

Emp.Code Desc.: CITY OF PAOLA, KANSAS

City of Paola

Pay Ending Date: 12/3/2022

Pay Date: 12/14/2022

Date: 12/7/2022

Time: 15:50:48

GL Number	Gross Pay	KP&F 22.99	Medicare	RETМ 1%	RETМ 8.9%	Soc Sec	Other
01-001-700.100	\$15,524.60	\$0.00	\$212.76	\$154.50	\$1,375.01	\$909.76	\$1,956.89
01-001-700.110	\$555.45	\$0.00	\$8.05	\$5.55	\$49.44	\$34.44	\$24.00
01-001-700.130	\$318.47	\$0.00	\$4.60	\$0.00	\$0.00	\$19.73	\$0.71
01-002-700.100	\$33,947.47	\$6,475.99	\$476.09	\$57.80	\$514.31	\$2,035.65	\$3,398.12
01-002-700.110	\$115.01	\$0.00	\$1.67	\$0.00	\$0.00	\$7.13	\$4.97
01-002-700.120	\$3,797.53	\$750.93	\$53.75	\$5.31	\$47.27	\$229.85	\$310.99
01-002-700.121	\$6,538.66	\$1,118.51	\$92.44	\$16.73	\$148.94	\$395.28	\$484.36
01-003-700.100	\$8,263.68	\$0.00	\$119.86	\$0.00	\$0.00	\$512.35	\$563.27
01-004-700.100	\$1,668.80	\$0.00	\$23.49	\$16.69	\$148.52	\$100.42	\$181.01
01-004-700.110	\$1,399.74	\$0.00	\$20.30	\$0.00	\$0.00	\$86.78	\$4.48
01-005-700.100	\$13,417.85	\$0.00	\$184.79	\$134.18	\$1,194.20	\$790.11	\$2,379.49
01-006-700.100	\$7,471.28	\$0.00	\$97.53	\$74.72	\$664.94	\$417.04	\$1,840.48
01-009-700.100	\$5,794.40	\$0.00	\$80.53	\$57.94	\$515.70	\$344.36	\$709.27
<b>Totals for Fund 01</b>	<b>\$98,812.94</b>	<b>\$8,345.43</b>	<b>\$1,375.86</b>	<b>\$523.42</b>	<b>\$4,658.33</b>	<b>\$5,882.90</b>	<b>\$11,858.04</b>
GL Number	Gross Pay	KP&F 22.99	Medicare	RETМ 1%	RETМ 8.9%	Soc Sec	Other
02-022-700.100	\$4,496.78	\$0.00	\$62.23	\$44.97	\$400.21	\$266.07	\$589.94
02-022-700.110	\$1,296.75	\$0.00	\$18.80	\$10.94	\$97.35	\$80.40	\$12.28
02-022-700.111	\$1,229.84	\$0.00	\$17.84	\$0.00	\$0.00	\$76.25	\$3.94
<b>Totals for Fund 02</b>	<b>\$7,023.37</b>	<b>\$0.00</b>	<b>\$98.87</b>	<b>\$55.91</b>	<b>\$497.56</b>	<b>\$422.72</b>	<b>\$606.16</b>
GL Number	Gross Pay	KP&F 22.99	Medicare	RETМ 1%	RETМ 8.9%	Soc Sec	Other
04-032-700.100	\$2,332.68	\$0.00	\$33.16	\$23.33	\$207.61	\$141.77	\$228.30

## Costs by GL Number Report

Sal Ord 22-26 CITY 12/14/22

Emp.Code Desc.: CITY OF PAOLA, KANSAS

City of Paola

Pay Ending Date: 12/3/2022

Pay Date: 12/14/2022

Date: 12/7/2022

Time: 15:50:48

04-033-700.100	\$5,026.79	\$0.00	\$67.71	\$50.28	\$447.38	\$289.56	\$1,090.72
04-033-700.120	\$61.35	\$0.00	\$0.84	\$0.60	\$5.46	\$3.56	\$7.30
<b>Totals for Fund 04</b>	<b>\$7,420.82</b>	<b>\$0.00</b>	<b>\$101.71</b>	<b>\$74.21</b>	<b>\$660.45</b>	<b>\$434.89</b>	<b>\$1,326.32</b>
<b>GL Number</b>	<b>Gross Pay</b>	<b>KP&amp;F 22.99</b>	<b>Medicare</b>	<b>RETm 1%</b>	<b>RETm 8.9%</b>	<b>Soc Sec</b>	<b>Other</b>
08-000-700.100	\$2,459.60	\$0.00	\$34.73	\$24.10	\$214.45	\$148.49	\$183.83
08-000-700.110	\$238.00	\$0.00	\$3.45	\$0.00	\$0.00	\$14.76	\$10.28
<b>Totals for Fund 08</b>	<b>\$2,697.60</b>	<b>\$0.00</b>	<b>\$38.18</b>	<b>\$24.10</b>	<b>\$214.45</b>	<b>\$163.25</b>	<b>\$194.11</b>
<b>GL Number</b>	<b>Gross Pay</b>	<b>KP&amp;F 22.99</b>	<b>Medicare</b>	<b>RETm 1%</b>	<b>RETm 8.9%</b>	<b>Soc Sec</b>	<b>Other</b>
09-033-700.100	\$1,407.20	\$0.00	\$20.40	\$14.07	\$125.24	\$87.25	\$62.33
09-033-700.120	\$35.18	\$0.00	\$0.51	\$0.35	\$3.13	\$2.18	\$1.56
<b>Totals for Fund 09</b>	<b>\$1,442.38</b>	<b>\$0.00</b>	<b>\$20.91</b>	<b>\$14.42</b>	<b>\$128.37</b>	<b>\$89.43</b>	<b>\$63.89</b>
<b>Grand Totals</b>	<b>\$117,397.11</b>	<b>\$8,345.43</b>	<b>\$1,635.53</b>	<b>\$692.06</b>	<b>\$6,159.16</b>	<b>\$6,993.19</b>	<b>\$14,048.52</b>

**SEAL: Stephanie D. Marler, City Clerk**

**Leigh House, Mayor**

**INVOICE APPROVAL LIST BY FUND REPORT**

APPR ORD #987 11/22

Date: 11/17/2022

Time: 10:49 am

Page: 1

City of Paola

Fund/Dept/Acct	Vendor Name	Invoice #	Invoice Desc.	Check #	Due Date	Posting Date	Amount
<b>Fund: 01 GENERAL OPERATING</b>							
<b>Dept: 001 ADMINISTRATION</b>							
01-001-700.220	LEGAL SERVICES TETWILER/LEE H.//	10692	CITY ATTORNEY FEE	71536	09/30/2022	11/30/2022	1,000.00
							<b>1,000.00</b>
01-001-700.230	TELEPHONE SERVIC LIGHTHOUSE BIS, LLC PC-02///	CLD-1091309	OCTOBER VOIP PHONE	0	10/31/2022	11/30/2022	212.81
							<b>212.81</b>
01-001-700.240	TRAINING, TRAVEL, I SHANNON/RANDI//		TUITION REIMBURSEMENT	0	11/15/2022	11/30/2022	3,456.90
							<b>3,456.90</b>
01-001-700.250	LEGAL PRINTING EXI NPG NEWSPAPERS INC 108948, NPG NEWSPAPERS INC 108948,	10/5/22 MR 6726000 10/26/22 MR 6728178	ADOPTION OF 2018 BUSINESS 3RD QUARTER TREASURERS	0 0	10/05/2022 10/26/2022	11/30/2022 11/30/2022	17.22 131.79
							<b>149.01</b>
01-001-700.290	OTHER CONTRACTU LIGHTHOUSE BIS, LLC PC-02/// LIGHTHOUSE BIS, LLC PC-02/// LIGHTHOUSE BIS, LLC PC-02/// OTIS ELEVATOR COMPANY INC. TOSHIBA FINANCIAL SVCS (CH) TOSHIBA FINANCIAL SVCS (CH) WASTE MGMT OF KS INC - 4856	RP-1091802 CLD-1091388 MSP-1091996 F10000061145 32736871 2102985 0568822-4856-2	NOVEMBER SECURITY OCTOBER CLOUD BACKUP NOVEMBER VOIP SUPPORT LOGISTICS AND FUEL IMPACT COPIER CONTRACT/USAGE COPIER RETURN CHARGE OCTOBER YARDWASTE	0 0 0 0 71537 71524 71538	11/01/2022 10/31/2022 11/01/2022 10/21/2022 10/31/2022 10/14/2022 11/01/2022	11/30/2022 11/30/2022 11/30/2022 11/30/2022 11/30/2022 11/30/2022 11/30/2022	115.00 169.00 198.00 125.00 569.04 1,719.63 1,668.20
							<b>4,563.87</b>
01-001-700.292	CIVIL DEFENSE SIRE EVERGY/// EVERGY///		ELECTRIC BILL PAYMENTS ELECTRIC BILL PAYMENTS	71539 71535	11/08/2022 11/07/2022	11/30/2022 11/30/2022	30.91 25.60
							<b>56.51</b>
01-001-700.293	STREET LIGHTS EVERGY///		ELECTRIC BILL PAYMENTS	71530	11/01/2022	11/30/2022	12,423.08
							<b>12,423.08</b>
01-001-700.310	OPERATIONAL SUPP WALMART COMMUNITY INC///	11/15/22 02353	KLEENEX	0	11/15/2022	11/30/2022	13.26
							<b>13.26</b>
<b>Total Dept. ADMINISTRATION:</b>							<b>21,875.44</b>
<b>Dept: 002 POLICE DEPARTMENT</b>							
01-002-700.240	TRAINING, TRAVEL, I ACTION TARGET/// ACTION TARGET///	0556999-IN 0556906-IN	TARGET TARGETS	0 0	11/07/2022 11/03/2022	11/30/2022 11/30/2022	1,294.68 186.44
							<b>1,481.12</b>
01-002-700.290	OTHER CONTRACTU LIGHTHOUSE BIS, LLC PC-02/// WASTE MGMT OF KS INC - 4856	RP-1091802 0568841-4856-2	NOVEMBER SECURITY OCTOBER TRASH REMOVAL	0 71531	11/01/2022 11/01/2022	11/30/2022 11/30/2022	325.00 76.58
							<b>401.58</b>
01-002-700.310	OPERATIONAL SUPP CE WATER MANAGEMENT INC// GERKEN RENT-ALL/// GERKEN RENT-ALL/// GERKEN RENT-ALL/// NAVRAT'S OFFICE PROD.-EMPC NAVRAT'S OFFICE PROD.-EMPC SHRED-IT/// THE GALLERY COLLECTION///	C62310 21796/7 21800/7 21798/7 0207468-001 0207467-001 8002528118 22E0053816	NOVEMBER CLOSED SYSTEM BOLTS & WASHERS WASHERS & NUTS WASHERS & NUTS CALENDARS, RECEIPT BOOK TONER SHREDDING SERVICE CHRISTMAS CARDS	0 0 0 0 0 0 0 0	11/01/2022 10/31/2022 10/31/2022 10/31/2022 11/01/2022 11/01/2022 10/03/2022 11/01/2022	11/30/2022 11/30/2022 11/30/2022 11/30/2022 11/30/2022 11/30/2022 11/30/2022 11/30/2022	220.00 6.68 1.00 3.99 208.13 158.00 99.65 183.80



**INVOICE APPROVAL LIST BY FUND REPORT**

APPR ORD #987 11/22

Date: 11/17/2022

Time: 10:49 am

Page: 3

City of Paola

Fund/Dept/Acct	Vendor Name	Invoice #	Invoice Desc.	Check #	Due Date	Posting Date	Amount
01-003-700.320	EQUIPMENT MAINTEN						
	KASPER AUTO PARTS, INC///	286290	TRANSMISSION FLUID #31 FIRE	0	11/03/2022	11/30/2022	45.99
	KASPER AUTO PARTS, INC///	286270	OIL & OIL FILTER #31 FIRE	0	11/03/2022	11/30/2022	258.78
	KASPER AUTO PARTS, INC///	286483	OIL & FILTER - HEAVY RESCUE	0	11/08/2022	11/30/2022	179.10
	O'REILLY AUTO PARTS INC///	0205-297276	ANTI-FREEZE	0	11/08/2022	11/30/2022	45.98
							<b>529.85</b>
01-003-700.330	BUILDING & MAINTEN						
	HOW CAN WE HELP LLC///	22-200	GYM ROOF WORK	0	09/28/2022	11/30/2022	715.59
	SMITH & SONS, INC./G.K.//	130780	ROOF VENTS & SHEET	0	11/01/2022	11/30/2022	319.45
							<b>1,035.04</b>
01-003-700.350	MOTOR FUEL & LUB						
	WEX BANK///	84816125	FIRE DEPARTMENT	71520	10/31/2022	11/30/2022	177.09
							<b>177.09</b>
01-003-700.351	RURAL FUEL						
	WEX BANK///	84849581	RURAL FIRE DEPARTMENT	71528	10/31/2022	11/30/2022	242.70
							<b>242.70</b>
01-003-700.370	UNIFORMS						
	DATCO, INC///	213408	97 - T SHIRTS WITH LOGOS	0	11/07/2022	11/30/2022	1,821.20
							<b>1,821.20</b>
01-003-700.371	PROTECTIVE CLOTH						
	FELD EQUIPMENT CO INC/ED M	0328022	FOUR SETS OF BUNKER	0	09/01/2022	11/30/2022	11,219.11
							<b>11,219.11</b>
							<b>Total Dept. FIRE DEPARTMENT: 17,370.69</b>
<b>Dept: 004 MUNICIPAL COURT</b>							
01-004-700.220	LEGAL SERVICES						
	CLYDE & WOOD, LLC///	100154	WILLIAMS, ANNE	0	10/30/2022	11/30/2022	70.00
	CLYDE & WOOD, LLC///	100114	LOVING, UVETTE	0	10/30/2022	11/30/2022	168.00
	CLYDE & WOOD, LLC///	100157	WILSON, JACQUALINE	0	10/30/2022	11/30/2022	14.00
	CLYDE & WOOD, LLC///	100156	WILSON, JACQUALINE	0	10/30/2022	11/30/2022	112.00
	CLYDE & WOOD, LLC///	100095	FORTNER, ALEXANDRYA	0	10/30/2022	11/30/2022	56.00
	CLYDE & WOOD, LLC///	100145	UNDERWOOD, KAYLA	0	10/30/2022	11/30/2022	35.00
	CLYDE & WOOD, LLC///	100143	THOMPSON, NATHAN	0	10/30/2022	11/30/2022	56.00
	CLYDE & WOOD, LLC///	100101	HILL, MICHAEL	0	10/30/2022	11/30/2022	56.00
	CLYDE & WOOD, LLC///	100102	HUSTON, NICOLE	0	10/30/2022	11/30/2022	70.00
	CLYDE & WOOD, LLC///	100111	LAVERACK, BRET	0	10/30/2022	11/30/2022	35.00
	CLYDE & WOOD, LLC///	100088	COLBERT, KACIE	0	10/30/2022	11/30/2022	56.00
	CLYDE & WOOD, LLC///	100153	WILKES, JR, MICHAEL	0	10/30/2022	11/30/2022	49.00
	CLYDE & WOOD, LLC///	100134	QUILLIN, STONE	0	10/30/2022	11/30/2022	77.00
	CLYDE & WOOD, LLC///	100131	NICKEL, SCOTT	0	10/30/2022	11/30/2022	91.00
	CLYDE & WOOD, LLC///	100130	NICKEL, SCOTT	0	10/30/2022	11/30/2022	70.00
	CLYDE & WOOD, LLC///	100129	NAVARRO, ANDREA	0	10/30/2022	11/30/2022	35.00
	CLYDE & WOOD, LLC///	100117	MARSHALL, ANDREW	0	10/30/2022	11/30/2022	35.00
	CLYDE & WOOD, LLC///	100121	MCKEEHAN, JAYALAN	0	10/30/2022	11/30/2022	63.00
	CLYDE & WOOD, LLC///	100087	CARTER, JASON	0	10/30/2022	11/30/2022	49.57
	CLYDE & WOOD, LLC///	100092	ELLER, MICHAEL	0	10/30/2022	11/30/2022	63.00
	CLYDE & WOOD, LLC///	100096	GILLESPIE, AARON	0	10/30/2022	11/30/2022	84.57
	CLYDE & WOOD, LLC///	100109	KUSSMAN, JACOB	0	10/30/2022	11/30/2022	49.00
	CLYDE & WOOD, LLC///	100108	KUSSMAN, JACOB	0	10/30/2022	11/30/2022	28.00
	TETWILER/LEE H.//	10693	CITY PROSECUTOR FEES	71536	09/30/2022	11/30/2022	3,937.50
							<b>5,359.64</b>
							<b>Total Dept. MUNICIPAL COURT: 5,359.64</b>
<b>Dept: 005 STREET DEPARTMENT</b>							
01-005-700.230	TELEPHONE SERVIC						
	LIGHTHOUSE BIS, LLC PC-02///	CLD-1091309	OCTOBER VOIP PHONE	0	10/31/2022	11/30/2022	116.30

**INVOICE APPROVAL LIST BY FUND REPORT**

APPR ORD #987 11/22

Date: 11/17/2022

Time: 10:49 am

Page: 4

City of Paola

Fund/Dept/Acct	Vendor Name	Invoice #	Invoice Desc.	Check #	Due Date	Posting Date	Amount
							<b>116.30</b>
01-005-700.280	UTILITIES						
	EVERGY///		ELECTRIC BILL PAYMENTS	71530	11/01/2022	11/30/2022	374.00
							<b>374.00</b>
01-005-700.290	OTHER CONTRACTU						
	COPY PRODUCTS, INC///	32736872	COPIER CONTRACT/USAGE	71533	10/31/2022	11/30/2022	28.91
	LIGHTHOUSE BIS, LLC PC-02///	RP-1091802	NOVEMBER SECURITY	0	11/01/2022	11/30/2022	50.00
							<b>78.91</b>
01-005-700.310	OPERATIONAL SUPP						
	CCL SUPPLY, LLC///	SO011464	HAND CLEANER	0	11/03/2022	11/30/2022	26.25
	FAMILY CENTER INC///	4128374	HAMMER	0	11/09/2022	11/30/2022	12.99
	WALMART COMMUNITY INC///	11/08/22 05252	PAPER	0	11/08/2022	11/30/2022	6.24
	WALMART COMMUNITY INC///	10/28/22 04321	BINDER CLIPS, BINDERS,	0	10/28/2022	11/30/2022	26.41
							<b>71.89</b>
01-005-700.315	VEHICLE MAINTENAN						
	KASPER AUTO PARTS, INC///	286045	BRAKE CLEANER	0	10/31/2022	11/30/2022	53.88
							<b>53.88</b>
01-005-700.320	EQUIPMENT MAINTEN						
	HEATHWOOD OIL CO., INC.///	H50220	20 TUBES LITHIUM GREASE	0	10/28/2022	11/30/2022	37.75
	KASPER AUTO PARTS, INC///	286628	WINDSHIELD DE-ICER, RAIN-X	0	11/10/2022	11/30/2022	62.86
	KASPER AUTO PARTS, INC///	286629	OIL FILTER WRENCH - #120	0	11/10/2022	11/30/2022	15.25
	ROADBUILDERS MCH & SUP IN	P59118	BATTERY - #120	0	11/07/2022	11/30/2022	580.00
							<b>695.86</b>
01-005-700.325	TRAFFIC EXPENSE						
	MID AMERICAN SIGNAL INC///	22-607	ADDITION OF DEDICATED	0	10/28/2022	11/30/2022	730.00
							<b>730.00</b>
01-005-700.350	MOTOR FUEL & LUB						
	WEX BANK///	84849580	STREET DEPARTMENT	71526	10/31/2022	11/30/2022	552.60
							<b>552.60</b>
01-005-700.370	UNIFORMS						
	UNIFIRST CORPORATION///	229 0097421	TOWELS & MATS	0	11/07/2022	11/30/2022	38.96
	UNIFIRST CORPORATION///	229 0097402	STREET DEPARTMENT	0	11/07/2022	11/30/2022	15.00
	UNIFIRST CORPORATION///	229 0100019	TOWELS & MATS	0	11/14/2022	11/30/2022	38.96
	UNIFIRST CORPORATION///	229 0099996	STREET DEPARTMENT	0	11/14/2022	11/30/2022	15.00
							<b>107.92</b>
							<b>Total Dept. STREET DEPARTMENT: 2,781.36</b>
<b>Dept: 006 PARKS &amp; GROUNDS</b>							
01-006-700.230	TELEPHONE SERVIC						
	LIGHTHOUSE BIS, LLC PC-02///	CLD-1091309	OCTOBER VOIP PHONE	0	10/31/2022	11/30/2022	47.22
							<b>47.22</b>
01-006-700.280	UTILITIES						
	EVERGY///		ELECTRIC BILL PAYMENTS	71539	11/08/2022	11/30/2022	61.29
	EVERGY///		ELECTRIC BILL PAYMENTS	71535	11/07/2022	11/30/2022	75.58
	EVERGY///		ELECTRIC BILL PAYMENTS	71535	11/07/2022	11/30/2022	18.14
	EVERGY///		ELECTRIC BILL PAYMENTS	71535	11/07/2022	11/30/2022	58.97
							<b>213.98</b>
01-006-700.290	OTHER CONTRACTU						
	COPY PRODUCTS, INC///	32736872	COPIER CONTRACT/USAGE	71533	10/31/2022	11/30/2022	28.91
	GERKEN RENT-ALL, INC.///	46027BU-1	PORTABLE TOILET RENTAL	0	11/05/2022	11/30/2022	78.00
	GERKEN RENT-ALL, INC.///	460790F-1	PORTABLE TOILET RENTAL	0	11/01/2022	11/30/2022	150.00
	LIGHTHOUSE BIS, LLC PC-02///	RP-1091802	NOVEMBER SECURITY	0	11/01/2022	11/30/2022	40.00

**INVOICE APPROVAL LIST BY FUND REPORT**

APPR ORD #987 11/22

Date: 11/17/2022

Time: 10:49 am

Page: 5

City of Paola

Fund/Dept/Acct	Vendor Name	Invoice #	Invoice Desc.	Check #	Due Date	Posting Date	Amount
	WASTE MGMT OF KS INC - 4856	0568676-4856-2	DUMPSTER LAKE MIOLA	71531	11/01/2022	11/30/2022	224.07
	WASTE MGMT OF KS INC - 4856	0568841-4856-2	OCTOBER TRASH REMOVAL	71531	11/01/2022	11/30/2022	270.35
	WASTE MGMT OF KS INC - 4856	0569363-4856-6	DUMPSTER SOUTH END	71531	11/03/2022	11/30/2022	68.32
	WASTE MGMT OF KS INC - 4856	0569362-4856-8	DUMPSTER LAKE MIOLA	71531	11/03/2022	11/30/2022	50.52
							<b>910.17</b>
01-006-700.310	OPERATIONAL SUPP						
	CCL SUPPLY, LLC///	SO011464	HAND CLEANER	0	11/03/2022	11/30/2022	26.25
	GERKEN RENT-ALL///	22063/7	PAINT STRIPPER, SCRUB	0	11/10/2022	11/30/2022	25.48
	WALMART COMMUNITY INC///	11/08/22 05252	PAPER	0	11/08/2022	11/30/2022	6.24
	WALMART COMMUNITY INC///	10/28/22 04321	BINDER CLIPS, BINDERS,	0	10/28/2022	11/30/2022	26.41
							<b>84.38</b>
01-006-700.320	EQUIPMENT MAINTENANCE						
	FAMILY CENTER INC///	4123299	CABLE & CLAMPS FOR	0	11/01/2022	11/30/2022	4.73
	HEATHWOOD OIL CO., INC.///	H50220	20 TUBES LITHIUM GREASE	0	10/28/2022	11/30/2022	37.75
							<b>42.48</b>
01-006-700.350	MOTOR FUEL & LUB						
	WEX BANK///	8486440	PARKS DEPARTMENT	71521	10/31/2022	11/30/2022	696.62
							<b>696.62</b>
01-006-700.370	UNIFORMS						
	UNIFIRST CORPORATION///	229 0097406	PARKS DEPARTMENT	0	11/07/2022	11/30/2022	17.24
	UNIFIRST CORPORATION///	229 0100000	PARKS DEPARTMENT	0	11/14/2022	11/30/2022	12.93
							<b>30.17</b>
							<b>Total Dept. PARKS &amp; GROUNDS: 2,025.02</b>
<b>Dept: 007 CEMETERY</b>							
01-007-700.350	MOTOR FUEL & LUB						
	WEX BANK///	84799157	CEMETERY DEPARTMENT	71518	10/31/2022	11/30/2022	31.39
							<b>31.39</b>
01-007-700.370	UNIFORMS						
	UNIFIRST CORPORATION///	229 0097403	CEMETERY DEPARTMENT	0	11/07/2022	11/30/2022	4.31
	UNIFIRST CORPORATION///	229 0099997	CEMETERY DEPARTMENT	0	11/14/2022	11/30/2022	4.31
							<b>8.62</b>
							<b>Total Dept. CEMETERY: 40.01</b>
<b>Dept: 009 COMMUNITY DEVELOPMENT</b>							
01-009-700.230	TELEPHONE SERVICE						
	LIGHTHOUSE BIS, LLC PC-02///	CLD-1091309	OCTOBER VOIP PHONE	0	10/31/2022	11/30/2022	70.24
							<b>70.24</b>
01-009-700.250	LEGAL PRINTING EXPENSE						
	NPG NEWSPAPERS INC 108948	10/19/22 MR 6727479	ORD #3194 STORAGE OPTION OF	0	10/19/2022	11/30/2022	53.76
							<b>53.76</b>
01-009-700.290	OTHER CONTRACTS						
	ALLENBRAND-DREWS & ASN IN	37463	BOUNDARY SURVEY & CERTIFICATE	0	11/08/2022	11/30/2022	3,275.00
	ALLENBRAND-DREWS & ASN IN	37465	ANGIERS ADDITION	0	11/08/2022	11/30/2022	1,300.00
	LIGHTHOUSE BIS, LLC PC-02///	RP-1091802	NOVEMBER SECURITY	0	11/01/2022	11/30/2022	30.00
	TOSHIBA FINANCIAL SVCS (CH)	32736871	COPIER CONTRACT/USAGE	71537	10/31/2022	11/30/2022	284.52
	TOSHIBA FINANCIAL SVCS (CH)	2102985	COPIER RETURN CHARGE	71524	10/14/2022	11/30/2022	859.82
							<b>5,749.34</b>
01-009-700.350	MOTOR FUEL & LUB						
	WEX BANK///	84870836	COMMUNITY DEVELOPMENT	71519	10/31/2022	11/30/2022	140.32
							<b>140.32</b>
							<b>Total Dept. COMMUNITY DEVELOPMENT: 6,013.66</b>



**INVOICE APPROVAL LIST BY FUND REPORT**

APPR ORD #987 11/22

Date: 11/17/2022

Time: 10:49 am

Page: 6

City of Paola

Fund/Dept/Acct	Vendor Name	Invoice #	Invoice Desc.	Check #	Due Date	Posting Date	Amount
<b>Fund GENERAL OPERATING:</b>							<b>65,708.56</b>
<b>Fund: 02 LIBRARY</b>							
<b>Dept: 022 LIBRARY</b>							
02-022-700.230	TELEPHONE SERVIC						
	LIGHTHOUSE BIS, LLC PC-02///	CLD-1091309	OCTOBER VOIP PHONE	0	10/31/2022	11/30/2022	127.91
							<b>127.91</b>
02-022-700.255	ADVERTISING EXPEN						
	NPG NEWSPAPER INC-104212///	10/12/2022 MR 75162878	ADVERTISING BOMC	0	11/01/2022	11/30/2022	150.00
							<b>150.00</b>
02-022-700.290	OTHER CONTRACTU						
	KSFIBERNET 0930000153///		NOVEMBER INTERNET	0	11/01/2022	11/30/2022	90.00
	LIGHTHOUSE BIS, LLC PC-02///	RP-1091802	NOVEMBER SECURITY	0	11/01/2022	11/30/2022	15.00
	LIGHTHOUSE BIS, LLC PFL-01///	CLD-1091385	OCTOBER BACKUP	0	10/31/2022	11/30/2022	109.00
	WASTE MGMT OF KS INC - 4856	0568841-4856-2	OCTOBER TRASH REMOVAL	71531	11/01/2022	11/30/2022	31.44
							<b>245.44</b>
02-022-700.300	GENERAL OFFICE SL						
	AMAZON PRIME - 6190///	AMAZON.COM*1K5NI97H0	AMZ PAPER	71534	10/10/2022	11/30/2022	12.49
							<b>12.49</b>
02-022-700.310	OPERATIONAL SUPP						
	AMAZON PRIME - 6190///	7 ZOOM.US 888-799-9666	WWW MONTHLY ZOOM	71534	10/17/2022	11/30/2022	14.99
	AMAZON PRIME - 6190///	\AMAZON.COM*H08DF4HU1	AMZ BREAKROOM SUPPLIES	71534	10/30/2022	11/30/2022	5.16
							<b>20.15</b>
02-022-700.330	BUILDING & MAINTEN						
	PROFESSIONAL TURF & TREE//	34775	PEST CONTROL	0	10/20/2022	11/30/2022	55.00
	SMITH & SONS, INC./G.K.//	130763	ALARM MONITORING SERVICE	0	10/17/2022	11/30/2022	200.00
							<b>255.00</b>
02-022-700.331	CLEANING SUPPLIES						
	AMAZON PRIME - 6190///	AMZN MKTP US*H82GW9BL1	A GLOVES	71534	10/23/2022	11/30/2022	9.88
	QUILL LLC///	28424726	TOILET PAPER	0	10/18/2022	11/30/2022	32.99
							<b>42.87</b>
02-022-700.344	LIBRARY MEDIA - GE						
	AMAZON PRIME - 6190///	MAZON.COM*144B769E0	AMZN 1 BOOK	71534	10/04/2022	11/30/2022	19.27
	AMAZON PRIME - 6190///	\AMZN MKTP US*1K0DC9Z30	A 1 DVD	71534	10/06/2022	11/30/2022	12.65
	AMAZON PRIME - 6190///	\AMAZON.COM*1K6TD94V1	AMZ 4 BOOKS	71534	10/06/2022	11/30/2022	57.08
	AMAZON PRIME - 6190///	\AMAZNO.COM*1K07T6PXO	AMZ 1 BOOK	71534	10/08/2022	11/30/2022	39.99
	AMAZON PRIME - 6190///	\AMAZON.COM*1K2OL64U2	AMZ 1 BOOK	71534	10/08/2022	11/30/2022	26.99
	AMAZON PRIME - 6190///	\AMAZON.COM*1K0DN18H1	AMZ 1 BOOK	71534	10/10/2022	11/30/2022	20.99
	AMAZON PRIME - 6190///	12 AMZN MKTP US*1K6KN1Y81	1 BOOK	71534	10/12/2022	11/30/2022	24.88
	AMAZON PRIME - 6190///	\AMAZON.COM*HT9TS0PD0	AMZ 15 BOOKS	71534	10/13/2022	11/30/2022	168.90
	AMAZON PRIME - 6190///	MAZON.COM*HT75Q2KMO	AMZ 1 BOOK	71534	10/16/2022	11/30/2022	14.99
	AMAZON PRIME - 6190///	\AMAZON.COM*H85CB5XX0	AMZ 1 BOOK	71534	10/20/2022	11/30/2022	14.99
	AMAZON PRIME - 6190///	\AMAZON.COM*H04W72L21	AMZ 1 BOOK	71534	10/26/2022	11/30/2022	26.99
	AMAZON PRIME - 6190///	\AMAZON.COM*H099X5XT1	AMZ 1 MUSIC CD	71534	10/29/2022	11/30/2022	8.37
	AMAZON PRIME - 6190///	AMAZON.COM*H095R24F2	AMZ 1 DVD	71534	10/31/2022	11/30/2022	19.96
	AMAZON PRIME - 6190///	1 &AMZN MKTP US*H039G64K2	1 DVD	71534	10/31/2022	11/30/2022	19.96
	AMAZON PRIME - 6190///	\AMAZON.COM*H00P83M82	AMZ 2 BOOKS	71534	11/02/2022	11/30/2022	31.20
	AMAZON PRIME - 6190///	AMAZON.COM AMZN.COM/BILL	BOOK ORDER REFUND	71534	11/02/2022	11/30/2022	-26.99
	BAKER & TAYLOR BOOKS INC.//	0003273142	BOOK REFUND	0	11/03/2022	11/30/2022	-11.78
	BAKER & TAYLOR BOOKS INC.//	2037121976	BOOKS & JACKETS	0	11/03/2022	11/30/2022	253.67
	BAKER & TAYLOR BOOKS INC.//	2037104409	BOOKS & JACKETS	0	10/28/2022	11/30/2022	35.16
	BAKER & TAYLOR BOOKS INC.//	2037087242	BOOKS & JACKETS	0	10/20/2022	11/30/2022	176.42
	BLACKSTONE PUBLISHING///	2071701	CD	0	11/02/2022	11/30/2022	42.95
	CENTER POINT LARGE PRINT///	1966380	BOOKS	0	11/01/2022	11/30/2022	46.74
	EBSCO INC///		SUBSCRIPTIONS	0	10/31/2022	11/30/2022	42.91

**INVOICE APPROVAL LIST BY FUND REPORT**

APPR ORD #987 11/22

Date: 11/17/2022

Time: 10:49 am

Page: 7

City of Paola

Fund/Dept/Acct	Vendor Name	Invoice #	Invoice Desc.	Check #	Due Date	Posting Date	Amount
							<b>1,066.29</b>
02-022-700.345	LIBRARY MATERIALS						
	WALMART COMMUNITY INC///	10/26/22 09602	RUBBING ALCOHOL & CANDY	0	10/26/2022	11/30/2022	2.98
							<b>2.98</b>
02-022-700.346	CHILDREN'S PROGR						
	AMAZON PRIME - 6190/// 3 AMZN MKTP US*1K2FT2OJ1 A		PROGRAMING SUPPLIES	71534	10/06/2022	11/30/2022	12.99
	AMAZON PRIME - 6190/// 3 AMZN MKTP US*1K9PX4N30 A		PROGRAMMING SUPPLIES	71534	10/06/2022	11/30/2022	9.46
	AMAZON PRIME - 6190/// 2 AMZN MKTP US*1K5RF1H82 A		1 BOOK	71534	10/12/2022	11/30/2022	12.99
	WALMART COMMUNITY INC///	10/26/22 09602	RUBBING ALCOHOL & CANDY	0	10/26/2022	11/30/2022	19.20
							<b>54.64</b>
02-022-700.402	COMPUTER EQUIP / :						
	AMAZON PRIME - 6190/// 3 AMZN MKTP US*H84ZY20W2 A		TONER CARTRIDGE	71534	10/23/2022	11/30/2022	22.99
	LIGHTHOUSE BIS, LLC PFL-01///	1092230	REMOTE SUPPORT	0	10/31/2022	11/30/2022	105.00
							<b>127.99</b>
02-022-700.440	LIBRARY MEDIA - CH						
	AMAZON PRIME - 6190/// 3 AMZN MKTP US*1K35R4FF1 A		1 BOOK	71534	10/06/2022	11/30/2022	28.98
	AMAZON PRIME - 6190/// 4 AMAZON.COM*H28ZM1120 AMZ		3 BOOKS	71534	11/02/2022	11/30/2022	37.27
	BOUND TO STAY BOUND///	186420	BOOKS	0	10/28/2022	11/30/2022	33.52
	PERMA-BOUND BOOKS	1935965-00	BOOKS	0	10/24/2022	11/30/2022	38.64
	PERMA-BOUND BOOKS	1934513-01	BOOK	0	11/07/2022	11/30/2022	12.37
							<b>150.78</b>
							<b>Total Dept. LIBRARY: 2,256.54</b>
							<b>Total Fund LIBRARY: 2,256.54</b>
<b>Fund: 04 SEWER SERVICE</b>							
<b>Dept: 001 ADMINISTRATION</b>							
04-001-700.230	TELEPHONE SERVIC						
	LIGHTHOUSE BIS, LLC PC-02///	CLD-1091309	OCTOBER VOIP PHONE	0	10/31/2022	11/30/2022	47.22
							<b>47.22</b>
04-001-700.290	OTHER CONTRACTU						
	LIGHTHOUSE BIS, LLC PC-02///	RP-1091802	NOVEMBER SECURITY	0	11/01/2022	11/30/2022	10.00
							<b>10.00</b>
							<b>Total Dept. ADMINISTRATION: 57.22</b>
<b>Dept: 032 PRODUCTION</b>							
04-032-700.280	UTILITIES						
	EVERGY///		ELECTRIC BILL PAYMENTS	71539	11/08/2022	11/30/2022	5,424.64
	EVERGY///		ELECTRIC BILL PAYMENTS	71535	11/07/2022	11/30/2022	120.44
	RURAL WATER DIST NO. 2 INC///		WATER USAGE 300 GALLONS	71529	10/28/2022	11/30/2022	22.01
							<b>5,567.09</b>
04-032-700.285	TESTING & ANALYTIC						
	JOHNSON COUNTY GOV///	202135	MONTHLY SAMPLES	0	11/03/2022	11/30/2022	284.00
							<b>284.00</b>
04-032-700.290	OTHER CONTRACTU						
	KWIKOM COMMUNICATIONS	B22056-49	DECEMBER INTERNET	0	11/14/2022	11/30/2022	95.00
							<b>95.00</b>
04-032-700.350	MOTOR FUEL & LUB						
	WEX BANK///	84864435	SEWER DEPARTMENT	71525	10/31/2022	11/30/2022	58.04
							<b>58.04</b>
04-032-700.370	UNIFORMS						
	UNIFIRST CORPORATION///	229 0097404	SEWER DEPARTMENT	0	11/07/2022	11/30/2022	4.31
	UNIFIRST CORPORATION///	229 0099998	SEWER DEPARTMENT	0	11/14/2022	11/30/2022	4.31

**INVOICE APPROVAL LIST BY FUND REPORT**

APPR ORD #987 11/22

Date: 11/17/2022

Time: 10:49 am

Page: 8

City of Paola

Fund/Dept/Acct	Vendor Name	Invoice #	Invoice Desc.	Check #	Due Date	Posting Date	Amount
							<b>8.62</b>
04-032-700.420	EQUIP/BLDG & GROU MOTION INDUSTRIES, INC///	MO36-01007534	BALL BEARINGS	0	11/04/2022	11/30/2022	403.59
							<b>403.59</b>
							<b>Total Dept. PRODUCTION: 6,416.34</b>
<b>Dept: 033 DISTRIBUTION (LINES)</b>							
04-033-700.280	UTILITIES COPY PRODUCTS, INC///	32736872	COPIER CONTRACT/USAGE	71533	10/31/2022	11/30/2022	28.92
							<b>28.92</b>
04-033-700.290	OTHER CONTRACTU KANSAS ONE-CALL SYSTEM IN	2100422	87 LOCATES	0	10/31/2022	11/30/2022	52.20
							<b>52.20</b>
04-033-700.310	OPERATIONAL SUPP CCL SUPPLY, LLC/// CORE & MAIN LP/// FASTENAL "MINNESOTA" INC/// PRETECH CORPORATION/// WALMART COMMUNITY INC/// WALMART COMMUNITY INC///	SO011464 R672931 KSOTT124577 25865 11/08/22 05252 10/28/22 04321	HAND CLEANER 2 - COUPLERS MARKING PAINT A LOCK FOR SEWER CONNECTIO PAPER BINDER CLIPS, BINDERS,	0 0 0 0 0 0	11/03/2022 11/03/2022 10/18/2022 10/31/2022 11/08/2022 10/28/2022	11/30/2022 11/30/2022 11/30/2022 11/30/2022 11/30/2022 11/30/2022	26.25 299.58 80.16 139.00 6.24 26.41
							<b>577.64</b>
04-033-700.320	EQUIPMENT MAINT KASPER AUTO PARTS, INC/// KASPER AUTO PARTS, INC/// KASPER AUTO PARTS, INC/// O'REILLY AUTO PARTS INC/// RED EQUIPMENT, LLC	286150 286325 286366 0205-297473 2665	WORK LIGHT #405 OIL & HYDRAULIC FILTER AIR FILTER - #405 OIL FILTER - #405 SUCTION ELBOW - #405	0 0 0 0 0	11/01/2022 11/04/2022 11/04/2022 11/09/2022 10/31/2022	11/30/2022 11/30/2022 11/30/2022 11/30/2022 11/30/2022	118.99 55.68 25.19 45.34 1,740.63
							<b>1,985.83</b>
04-033-700.350	MOTOR FUEL & LUB WEX BANK///	84799161	SEWER DEPARTMENT	71523	10/31/2022	11/30/2022	1,937.80
							<b>1,937.80</b>
04-033-700.370	UNIFORMS UNIFIRST CORPORATION/// UNIFIRST CORPORATION///	229 0097404 229 0099998	SEWER DEPARTMENT SEWER DEPARTMENT	0 0	11/07/2022 11/14/2022	11/30/2022 11/30/2022	13.37 9.06
							<b>22.43</b>
04-033-700.420	EQUIP/BLDG & GROU SENSAPHONE	00291877	SENTINEL CELLULAR BATTERY	0	11/02/2022	11/30/2022	101.48
							<b>101.48</b>
							<b>Total Dept. DISTRIBUTION (LINES): 4,706.30</b>
							<b>Total Fund SEWER SERVICE: 11,179.86</b>
<b>Fund: 05 EMPLOYEE BENEFIT</b>							
<b>Dept: 000</b>							
05-000-700.139	HRA PREMIUMS SURENCY LIFE & HEALTH///		OCTOBER/NOVEMBER COBRA,	0	11/15/2022	11/30/2022	609.00
							<b>609.00</b>
05-000-700.140	HEALTH INSURANCE DELTA DENTAL OF KANSAS INC	1000147202211	NOVEMBER DENTAL INSURANCE	71532	10/31/2022	11/30/2022	1,392.93
							<b>1,392.93</b>
05-000-700.141	COBRA INSURANCE   DELTA DENTAL OF KANSAS INC	1000147202211	NOVEMBER DENTAL INSURANCE	71532	10/31/2022	11/30/2022	53.90
							<b>53.90</b>

**INVOICE APPROVAL LIST BY FUND REPORT**

APPR ORD #987 11/22

Date: 11/17/2022

Time: 10:49 am

Page: 9

City of Paola

Fund/Dept/Acct	Vendor Name	Invoice #	Invoice Desc.	Check #	Due Date	Posting Date	Amount
05-000-700.289	EMPLOYEE ASSISTANT						
	COMPLIANCEONE///	298402	OCTOBER - 17 ACTIVE	0	11/08/2022	11/30/2022	102.85
	COMPLIANCEONE///	298403	OCTOBER - 17 ACTIVE	0	11/08/2022	11/30/2022	122.65
							<b>225.50</b>
							<b>Total Dept. 000: 2,281.33</b>
							<b>Total Fund EMPLOYEE BENEFIT: 2,281.33</b>
<b>Fund: 07 FAMILY AQUATICS CENTER</b>							
<b>Dept: 000</b>							
07-000-700.230	TELEPHONE SERVICE						
	LIGHTHOUSE BIS, LLC PC-02///	CLD-1091309	OCTOBER VOIP PHONE	0	10/31/2022	11/30/2022	58.73
							<b>58.73</b>
							<b>Total Dept. 000: 58.73</b>
							<b>Total Fund FAMILY AQUATICS CENTER: 58.73</b>
<b>Fund: 08 COMMUNITY CENTER</b>							
<b>Dept: 000</b>							
08-000-700.230	TELEPHONE SERVICE						
	LIGHTHOUSE BIS, LLC PC-02///	CLD-1091309	OCTOBER VOIP PHONE	0	10/31/2022	11/30/2022	42.88
							<b>42.88</b>
08-000-700.255	ADVERTISING EXPENSE						
	MORRIS/BROOK//	2119	SOCIAL MEDIA PLATFORM	0	11/14/2022	11/30/2022	70.00
							<b>70.00</b>
08-000-700.290	OTHER CONTRACTS						
	LIGHTHOUSE BIS, LLC PC-02///	RP-1091802	NOVEMBER SECURITY	0	11/01/2022	11/30/2022	10.00
	WASTE MGMT OF KS INC - 4856	0568841-4856-2	OCTOBER TRASH REMOVAL	71531	11/01/2022	11/30/2022	38.02
							<b>48.02</b>
08-000-700.300	GENERAL OFFICE SUPPLIES						
	NAVRAT'S OFFICE PROD.-EMPC	0207764-001	CHAIR MAT	0	11/08/2022	11/30/2022	129.99
							<b>129.99</b>
08-000-700.310	OPERATIONAL SUPPLIES						
	4 STATE MAINTENANCE SUPPLY	647609	CENTERPULL TOWELS	0	11/01/2022	11/30/2022	128.90
							<b>128.90</b>
08-000-700.330	BUILDING & MAINTENANCE						
	OTIS ELEVATOR COMPANY INC.	F10000061146	LOGISTICS AND FUEL IMPACT	0	10/21/2022	11/30/2022	125.00
							<b>125.00</b>
							<b>Total Dept. 000: 544.79</b>
							<b>Total Fund COMMUNITY CENTER: 544.79</b>
<b>Fund: 09 WATER UTILITY</b>							
<b>Dept: 001 ADMINISTRATION</b>							
09-001-700.230	TELEPHONE SERVICE						
	LIGHTHOUSE BIS, LLC PC-02///	CLD-1091309	OCTOBER VOIP PHONE	0	10/31/2022	11/30/2022	47.22
							<b>47.22</b>
09-001-700.290	OTHER CONTRACTS						
	LIGHTHOUSE BIS, LLC PC-02///	RP-1091802	NOVEMBER SECURITY	0	11/01/2022	11/30/2022	20.00
							<b>20.00</b>
							<b>Total Dept. ADMINISTRATION: 67.22</b>

Dept: 032 PRODUCTION

**INVOICE APPROVAL LIST BY FUND REPORT**

APPR ORD #987 11/22

Date: 11/17/2022

Time: 10:49 am

Page: 10

City of Paola

Fund/Dept/Acct	Vendor Name	Invoice #	Invoice Desc.	Check #	Due Date	Posting Date	Amount
09-032-700.240	TRAINING, TRAVEL, I AMERICAN WATERWORKS ASSI	7002053597	MEMBERSHIP RENEWAL	0	09/18/2022	11/30/2022	174.00
							<b>174.00</b>
09-032-700.299	WATER PURCHASE - MARAIS DES CYGNES PUA///	2022-11-P	WATER USAGE 10/14-11/15/22	71540	11/15/2022	11/30/2022	143,979.91
							<b>143,979.91</b>
						<b>Total Dept. PRODUCTION:</b>	<b>144,153.91</b>
<b>Dept: 033 DISTRIBUTION (LINES)</b>							
09-033-700.240	TRAINING, TRAVEL, I AMERICAN WATERWORKS ASSI	7002053597	MEMBERSHIP RENEWAL	0	09/18/2022	11/30/2022	174.00
							<b>174.00</b>
09-033-700.280	UTILITIES RURAL WATER DIST NO. 2 INC//		WATER USAGE 2,350 GALLONS	71529	10/16/2022	11/30/2022	28.83
							<b>28.83</b>
09-033-700.290	OTHER CONTRACTU COPY PRODUCTS, INC/// KANSAS ONE-CALL SYSTEM IN	32736872 2100422	COPIER CONTRACT/USAGE 87 LOCATES	71533 0	10/31/2022 10/31/2022	11/30/2022 11/30/2022	28.92 52.20
							<b>81.12</b>
09-033-700.310	OPERATIONAL SUPP CCL SUPPLY, LLC/// CORE & MAIN LP/// CORE & MAIN LP/// CORE & MAIN LP/// CORE & MAIN LP/// FAMILY CENTER INC/// FASTENAL "MINNESOTA" INC/// FASTENAL "MINNESOTA" INC/// WALMART COMMUNITY INC/// WALMART COMMUNITY INC///	SO011464 R811620 R816906 R815378 R811507 4124614 KSOTT124633 KSOTT124577 11/08/22 05252 10/28/22 04321	HAND CLEANER 20 - 20' PVC PIPES GATE VALVE, MECHANICAL JOINT DESCALER PIPE 2 - HYMAX COUPLINGS ANTI FREEZE FOR WINTERIZATIO BLUE MARKING PAINT MARKING PAINT PAPER BINDER CLIPS, BINDERS,	0 0 0 0 0 0 0 0 0 0	11/03/2022 11/03/2022 11/02/2022 11/02/2022 11/02/2022 11/03/2022 10/24/2022 10/18/2022 11/08/2022 10/28/2022	11/30/2022 11/30/2022 11/30/2022 11/30/2022 11/30/2022 11/30/2022 11/30/2022 11/30/2022 11/30/2022 11/30/2022	26.25 798.60 1,750.66 215.41 987.78 23.97 114.77 114.77 6.25 26.41
							<b>4,064.87</b>
09-033-700.340	CONSTRUCTION MA1 GERKEN RENT-ALL, INC.///	511639-1	CONCRETE DELIVERY	0	11/09/2022	11/30/2022	697.50
							<b>697.50</b>
09-033-700.350	MOTOR FUEL & LUB WEX BANK///	84856441	WATER DEPARTMENT FUEL	71527	10/31/2022	11/30/2022	971.22
							<b>971.22</b>
09-033-700.370	UNIFORMS UNIFIRST CORPORATION/// UNIFIRST CORPORATION///	229 0097405 229 0099999	WATER DEPARTMENT WATER DEPARTMENT	0 0	11/07/2022 11/14/2022	11/30/2022 11/30/2022	4.31 8.62
							<b>12.93</b>
						<b>Total Dept. DISTRIBUTION (LINES):</b>	<b>6,030.47</b>
						<b>Total Fund WATER UTILITY:</b>	<b>150,251.60</b>
<b>Fund: 13 HEALTH AND SANITATION</b>							
<b>Dept: 032 PRODUCTION</b>							
13-032-700.290	OTHER CONTRACTU WASTE MGMT OF KS INC - 4856	0568833-4856-9	OCTOBER TRASH REMOVAL	71531	11/01/2022	11/30/2022	35,050.22
							<b>35,050.22</b>
						<b>Total Dept. PRODUCTION:</b>	<b>35,050.22</b>
						<b>nd HEALTH AND SANITATION:</b>	<b>35,050.22</b>

**INVOICE APPROVAL LIST BY FUND REPORT**

APPR ORD #987 11/22

Date: 11/17/2022

Time: 10:49 am

Page: 11

City of Paola

Fund/Dept/Acct	Vendor Name	Invoice #	Invoice Desc.	Check #	Due Date	Posting Date	Amount
<b>Fund: 27 SALES TAX PROJECTS 2022</b>							
<b>Dept: 000</b>							
27-000-700.290	OTHER CONTRACTU						
	KAW VALLEY ENGINEERING, IN	A48109	LAKE MIOLA DAM REPAIR	0	11/01/2022	11/30/2022	4,515.00
							<u>4,515.00</u>
						<b>Total Dept. 000:</b>	<b>4,515.00</b>
						<b>SALES TAX PROJECTS 2022:</b>	<b>4,515.00</b>
<b>Fund: 70 SPECIAL GRANTS</b>							
<b>Dept: 701 LIBRARY - BAHER GRANT</b>							
70-701-700.345	LIBRARY MATERIALS						
	MIDWEST TAPE, LLC///	502900978	OCTOBER DIGITAL	0	10/31/2022	11/30/2022	477.47
							<u>477.47</u>
						<b>Total Dept. LIBRARY - BAHER GRANT:</b>	<b>477.47</b>
						<b>Total Fund SPECIAL GRANTS:</b>	<b>477.47</b>
<b>Fund: 90 CIP - CAPITAL IMPROVEMEN</b>							
<b>Dept: 304 CIP - COMMUNITY CTR REM</b>							
90-304-700.435	MISCELLANEOUS CA						
	SMITH & SONS, INC./G.K.//	000096450000	THREE HEAT PUMP	0	10/30/2022	11/30/2022	28,905.00
							<u>28,905.00</u>
						<b>Total Dept. CIP - COMMUNITY CTR REMODEL:</b>	<b>28,905.00</b>
<b>Dept: 316 CIP - FIRE DEPT BUILDING</b>							
90-316-700.390	MISCELLANEOUS						
	KA-COMM INC///	186108	WATER TOWER ICE	0	11/03/2022	11/30/2022	3,787.36
	KA-COMM INC///	186109	RELOCATION OF VHF RADIO	0	11/03/2022	11/30/2022	605.00
							<u>4,392.36</u>
						<b>Total Dept. CIP - FIRE DEPT BUILDING:</b>	<b>4,392.36</b>
						<b>APITAL IMPROVEMENT PROJ:</b>	<b>33,297.36</b>
						<b>Grand Total:</b>	<b>305,621.46</b>

**INVOICE APPROVAL LIST BY FUND REPORT**

APPR ORD #988 12/7/22

Date: 12/07/2022

Time: 4:58 pm

Page: 1

City of Paola

Fund/Dept/Acct	Vendor Name	Invoice #	Invoice Desc.	Check #	Due Date	Posting Date	Amount	
<b>Fund: 01 GENERAL OPERATING</b>								
<b>Dept: 000</b>								
01-000-400.330	REIMBURSED EXPEN							
	VISA - 1348	09/30/22	REBATE CREDIT	REBATE CREDIT	71612	09/30/2022	11/30/2022	-83.64
								<b>-83.64</b>
								<b>Total Dept. 000: -83.64</b>
<b>Dept: 001 ADMINISTRATION</b>								
01-001-700.220	LEGAL SERVICES							
	TETWILER/LEE H.//	10694	OCTOBER CITY ATTORNEY		71625	10/31/2022	11/30/2022	1,062.50
								<b>1,062.50</b>
01-001-700.230	TELEPHONE SERVIC							
	LIGHTHOUSE BIS, LLC PC-02///	CLD-1092454	NOVEMBER VOIP PHONE		0	11/30/2022	11/30/2022	208.72
								<b>208.72</b>
01-001-700.240	TRAINING, TRAVEL, [							
	VISA - 1348	8 KU WEB PAYMENT SERVICES	TRAINING INSPIRING WOMEN		71612	10/08/2022	11/30/2022	160.00
								<b>160.00</b>
01-001-700.280	UTILITIES							
	EVERGY///		ELECTRIC BILL PAYMENTS		71622	11/21/2022	11/30/2022	466.30
	KANSAS GAS SERVICE INC///		GAS BILL PAYMENTS		71610	11/14/2022	11/30/2022	59.07
								<b>525.37</b>
01-001-700.290	OTHER CONTRACTU							
	CONLEY SPRINKLER, INC///	13273	ANNUAL FIRE SPRINKLER SYSTEI		0	11/21/2022	11/30/2022	364.00
	GFI DIGITAL///	2397369	COPIER USAGE CHARGE		0	11/23/2022	11/30/2022	41.44
	KSFIBERNET 0930000160///		DECEMBER INTERNET		0	12/01/2022	11/30/2022	200.00
	LIGHTHOUSE BIS, LLC PC-02///	RP-1092886	DECEMBER SECURITY		0	12/01/2022	11/30/2022	115.00
	LIGHTHOUSE BIS, LLC PC-02///	MSP-1093065	DECEMBER VOIP SUPPORT		0	12/01/2022	11/30/2022	198.00
	LIGHTHOUSE BIS, LLC PC-02///	CLD-1092387	NOVEMBER CLOUD BACKUP		0	11/30/2022	11/30/2022	169.00
	MIAMI COUNTY TREASURER///	22976	1205 INDUSTRIAL PARK DRIVE		0	11/05/2022	11/30/2022	419.17
	MIAMI COUNTY TREASURER///	37876	TAX ON AMERICAN TOWER		0	11/05/2022	11/30/2022	913.16
	OTIS ELEVATOR COMPANY INC,	100400983535	DECEMBER MAINTENANCE		0	11/14/2022	11/30/2022	107.52
	PITNEY BOWES INC-981022	3316623429	LEASE PAYMENT 9/30-12/29/2022		0	11/25/2022	11/30/2022	190.20
	SHRED-IT///	8002817430	SHREDDING SERVICE		0	11/25/2022	11/30/2022	96.33
	U.S. POSTMASTER///		2022 RENT FOR PO BOX 409		0	12/05/2022	11/30/2022	218.00
	VISA - 1348	15 CANVA*103574-15384290 HT	CANVA PRO SUBSCRIPTION		71612	10/15/2022	11/30/2022	12.99
								<b>3,044.81</b>
01-001-700.292	CIVIL DEFENSE SIRE							
	EVERGY///		ELECTRIC BILL PAYMENTS		71609	11/14/2022	11/30/2022	7.92
	EVERGY///		ELECTRIC BILL PAYMENTS		71609	11/14/2022	11/30/2022	7.92
	EVERGY///		ELECTRIC BILL PAYMENTS		71609	11/14/2022	11/30/2022	7.92
	EVERGY///		ELECTRIC BILL PAYMENTS		71614	11/18/2022	11/30/2022	30.09
	EVERGY///		ELECTRIC BILL PAYMENTS		71613	11/18/2022	11/30/2022	30.44
								<b>84.29</b>
01-001-700.293	STREET LIGHTS							
	EVERGY///		ELECTRIC BILL PAYMENTS		71626	12/01/2022	11/30/2022	12,398.25
								<b>12,398.25</b>
01-001-700.300	GENERAL OFFICE SL							
	AMERICAN SOLUTIONS FOR///	INV06406245	TAX FORMS		0	11/29/2022	11/30/2022	211.45
	VISA - 1348	8 AMZN MKTP US*HT72X4911 A	PARCHMENT CARDSTOCK		71612	10/18/2022	11/30/2022	18.48
	VISA - 1348	AMAZON.COM*H85IA3LK0 AMZ	PENCIL LEADS		71612	10/18/2022	11/30/2022	4.22
	VISA - 1348	AMZN MKTP US*H89HO3ZU1 A	NAME PLATES		71612	10/20/2022	11/30/2022	7.55
	VISA - 1348	AMAZON.COM*H840R8VA1 AMZ	MANILA FILES		71612	10/22/2022	11/30/2022	50.81
								<b>292.51</b>
01-001-700.301	POSTAGE							
	PITNEY BOWES INC 223648 RE:	#4 11/17/2022	POSTAGE		0	11/17/2022	11/30/2022	333.34

**INVOICE APPROVAL LIST BY FUND REPORT**

APPR ORD #988 12/7/22

Date: 12/07/2022

Time: 4:58 pm

Page: 2

City of Paola

Fund/Dept/Acct	Vendor Name	Invoice #	Invoice Desc.	Check #	Due Date	Posting Date	Amount
	U.S. POSTMASTER///		UTILITY BILL MAILING	71624	11/30/2022	11/30/2022	191.14
							<b>524.48</b>
01-001-700.305	GIFTS / MEMORIALS						
	CHILDREN'S MERCY HOSPITAL		AMELIA COX MEMORIAL	0	11/30/2022	11/30/2022	50.00
							<b>50.00</b>
01-001-700.310	OPERATIONAL SUPP						
	4 STATE MAINTENANCE SUPPL	648752	CENTERPULL TOWELS	0	11/29/2022	11/30/2022	287.23
	WALMART COMMUNITY INC///	11/28/22 4175	LIGHT BULBS	0	11/28/2022	11/30/2022	8.91
							<b>296.14</b>
01-001-700.390	MISCELLANEOUS						
	MARAI DES CYGNES PUA///	47927	JMZ CORPORATION PAYMENT	0	11/07/2022	11/30/2022	2,000.00
	UNITED STATES TREASURY///		SECTION 6721 ASSESSMENT	71623	11/29/2022	11/30/2022	13,840.00
	WALMART COMMUNITY INC///	11/18/22 06811	SNACKS FOR REC DIRECTOR	71621	11/18/2022	11/30/2022	19.74
							<b>15,859.74</b>
01-001-700.402	COMPUTER EQUIP / :						
	VISA - 1348		0 AMZN MKTP US*140B26301 A BATTERIES	71612	09/30/2022	11/30/2022	84.14
							<b>84.14</b>
							<b>Total Dept. ADMINISTRATION: 34,590.95</b>
<b>Dept: 002 POLICE DEPARTMENT</b>							
01-002-700.230	TELEPHONE SERVIC						
	VERIZON///	9920094229	CELL PHONE PAYMENT	71617	11/09/2022	11/30/2022	577.62
							<b>577.62</b>
01-002-700.240	TRAINING, TRAVEL, [						
	VISA - 1348		AW ENFORCEMENT SEMINARS SEMINAR - RECRUITING FOR LAW	71612	10/19/2022	11/30/2022	395.00
	VISA - 1348	200076728	FBI-LEEDA - COMMAND LEADERS	71612	10/19/2022	11/30/2022	695.00
	VISA - 1348	PS-INV0134431	VIRTUAL CHEMICAL AEROSOL	71612	10/24/2022	11/30/2022	90.00
	VISA - 1348	2 KU WEB PMT SVCS CED 785-	KU CLASS - GONZALEZ	71612	10/12/2022	11/30/2022	225.00
							<b>1,405.00</b>
01-002-700.272	ANIMAL CARE						
	CITY OF OSAWATOMIE///		OCTOBER ANIMAL	0	11/09/2022	11/30/2022	973.00
							<b>973.00</b>
01-002-700.280	UTILITIES						
	EVERGY///		ELECTRIC BILL PAYMENTS	71613	11/18/2022	11/30/2022	21.88
	EVERGY///		ELECTRIC BILL PAYMENTS	71613	11/18/2022	11/30/2022	1,648.62
	KANSAS GAS SERVICE INC///		GAS BILL PAYMENTS	71610	11/14/2022	11/30/2022	62.71
							<b>1,733.21</b>
01-002-700.290	OTHER CONTRACTU						
	KSFIBERNET 0930000160///		DECEMBER INTERNET	0	12/01/2022	11/30/2022	200.00
	LIGHTHOUSE BIS, LLC PC-02///	RP-1092886	DECEMBER SECURITY	0	12/01/2022	11/30/2022	305.00
	TOSHIBA FINANCIAL SERVICES	5022641223	COPIER CONTRACT/USAGE	0	11/10/2022	11/30/2022	482.94
	VERIZON///	9920094229	CELL PHONE PAYMENT	71617	11/09/2022	11/30/2022	160.44
							<b>1,148.38</b>
01-002-700.310	OPERATIONAL SUPP						
	FIVE-O LLC	2022-PAOLA-03	POLYGRAPH SERVICE	0	08/24/2022	11/30/2022	400.00
	PAT'S SIGNS///	6379	2023 ATV STICKERS	0	11/14/2022	11/30/2022	67.50
	QUEEN ENTERPRISES, LLC///		MEAL FOR THANKSGIVING	0	11/24/2022	11/30/2022	88.46
	SHRED-IT///	8002727074	SHREDDING SERVICE	71616	11/03/2022	11/30/2022	200.04
	VISA - 1348	7 AMZN MKTP US*HT82603J2 A	DISPOSABLE DIXIE HOT CUPS	71612	10/12/2022	11/30/2022	101.96
	VISA - 1348	GOOGLE*YOUTUBE TV SUPPOR	GOOGLE YOU TUBE TV	71612	10/01/2022	11/30/2022	70.19
	WALMART COMMUNITY INC///	11/19/22 02946	PAPER TOWELS, LIQUID	71621	11/19/2022	11/30/2022	49.38
	WALMART COMMUNITY INC///	11/21/22 07035	BATTERIES	0	11/21/2022	11/30/2022	39.96
							<b>1,017.49</b>
01-002-700.315	VEHICLE MAINTENAN						



**INVOICE APPROVAL LIST BY FUND REPORT**

APPR ORD #988 12/7/22

Date: 12/07/2022

Time: 4:58 pm

Page: 3

City of Paola

Fund/Dept/Acct	Vendor Name	Invoice #	Invoice Desc.	Check #	Due Date	Posting Date	Amount
	KASPER AUTO PARTS, INC///	287246	CLIPS PD#2	0	11/21/2022	11/30/2022	8.99
							<b>8.99</b>
01-002-700.350	MOTOR FUEL & LUB						
	WEX BANK///	85570926	POLICE DEPARTMENT	0	11/30/2022	11/30/2022	2,773.83
							<b>2,773.83</b>
01-002-700.370	UNIFORMS						
	GERKEN RENT-ALL///	22070/7	BRASS PULL CHAINS	0	11/10/2022	11/30/2022	7.58
							<b>7.58</b>
01-002-700.402	COMPUTER EQUIP / :						
	VISA - 1348	7/22 AMZN MKTP US*HT82603J	LASER PRINTER	71612	12/02/2022	11/30/2022	593.01
	VISA - 1348	07 ADOBE *ADOBE 408-536-600	ADOBE ACROBAT PRO PLAN	71612	10/07/2022	11/30/2022	314.51
	VISA - 1348	20 ADOBE *ADOBE 4085366000	TAX REFUND	71612	10/20/2022	11/30/2022	-26.63
	VISA - 1348	OFFICEMAX/OFFICEDEPT#687	2 - BLACK TONER CARTRIDGES	71612	10/19/2022	11/30/2022	107.78
	VISA - 1348	OFFICEMAX/OFFICEDEPT #68	2 - MULTI COLOR PACKS OF	71612	10/19/2022	11/30/2022	467.12
							<b>1,455.79</b>
01-002-700.430	MOTOR VEHICLE/EQ						
	SHORE TIRE CO., INC.///	319420	4 GOODYEAR EAGLE RS-A	0	11/22/2022	11/30/2022	980.44
							<b>980.44</b>
							<b>Total Dept. POLICE DEPARTMENT: 12,081.33</b>
<b>Dept: 003 FIRE DEPARTMENT</b>							
01-003-700.230	TELEPHONE SERVIC						
	LIGHTHOUSE BIS, LLC PC-02///	CLD-1092454	NOVEMBER VOIP PHONE	0	11/30/2022	11/30/2022	197.19
	VERIZON///	9920094229	CELL PHONE PAYMENT	71617	11/09/2022	11/30/2022	41.41
							<b>238.60</b>
01-003-700.260	INSURANCE						
	ELLIOTT INSURANCE INC///	6080	ADDED LOCATION	0	11/03/2022	11/30/2022	80.00
							<b>80.00</b>
01-003-700.280	UTILITIES						
	EVERGY///		ELECTRIC BILL PAYMENTS	71613	11/18/2022	11/30/2022	21.87
	EVERGY///		ELECTRIC BILL PAYMENTS	71622	11/21/2022	11/30/2022	875.22
	KANSAS GAS SERVICE INC///		GAS BILL PAYMENTS	71610	11/14/2022	11/30/2022	52.88
							<b>949.97</b>
01-003-700.290	OTHER CONTRACTU						
	HENSON/BRADLEY E.//	22-043	FIRE PLAN RESUBMITTAL	0	11/28/2022	11/30/2022	50.00
	HENSON/BRADLEY E.//	22-042	FIRE PLAN REVIEW RESUBMITTAL	0	11/17/2022	11/30/2022	50.00
	KSFIBERNET 0930000160///		DECEMBER INTERNET	0	12/01/2022	11/30/2022	200.00
	LIGHTHOUSE BIS, LLC PC-02///	RP-1092886	DECEMBER SECURITY	0	12/01/2022	11/30/2022	80.00
	VERIZON///	9920094229	CELL PHONE PAYMENT	71617	11/09/2022	11/30/2022	120.03
							<b>500.03</b>
01-003-700.330	BUILDING & MAINTEN						
	VISA - 1348	'11 1000BULBS.COM 800-624-44	2 - TUBE LAMPS	71612	10/11/2022	11/30/2022	317.08
							<b>317.08</b>
01-003-700.350	MOTOR FUEL & LUB						
	WEX BANK///	85539294	FIRE DEPARTMENT	0	11/30/2022	11/30/2022	117.39
							<b>117.39</b>
01-003-700.351	RURAL FUEL						
	WEX BANK///	85584689	RURAL FIRE DEPARTMENT	0	11/30/2022	11/30/2022	223.46
							<b>223.46</b>
01-003-700.402	COMPUTER EQUIP / :						
	VISA - 1348	0/13 ACTIVE911 INC 541-223-79	ACTIVE ALERT ALERTING	71612	10/13/2022	11/30/2022	300.00
							<b>300.00</b>

**INVOICE APPROVAL LIST BY FUND REPORT**

APPR ORD #988 12/7/22

Date: 12/07/2022

Time: 4:58 pm

Page: 4

City of Paola

Fund/Dept/Acct	Vendor Name	Invoice #	Invoice Desc.	Check #	Due Date	Posting Date	Amount
<b>Total Dept. FIRE DEPARTMENT:</b>							<b>2,726.53</b>
<b>Dept: 004 MUNICIPAL COURT</b>							
01-004-700.220 LEGAL SERVICES							
	CLYDE & WOOD, LLC///	100208	LOVING, UVETTE	0	11/30/2022	11/30/2022	224.00
	CLYDE & WOOD, LLC///	100183	CARTER, JASON	0	11/30/2022	11/30/2022	42.00
	CLYDE & WOOD, LLC///	100195	GILLESPIE, AARON	0	11/30/2022	11/30/2022	154.00
	CLYDE & WOOD, LLC///	100222	NAVARRO, ANDREA	0	11/30/2022	11/30/2022	98.00
	CLYDE & WOOD, LLC///	100211	MARSHALL, ANDREW	0	11/30/2022	11/30/2022	84.00
	CLYDE & WOOD, LLC///	100194	FORTNER, ALEXANDRYA	0	11/30/2022	11/30/2022	63.00
	CLYDE & WOOD, LLC///	100181	CARL, SHIRLEY	0	11/30/2022	11/30/2022	35.00
	CLYDE & WOOD, LLC///	100212	MCKEEHAN, JAYALAN	0	11/30/2022	11/30/2022	56.00
	CLYDE & WOOD, LLC///	100244	WILLIAMS, ANNE	0	11/30/2022	11/30/2022	1.14
	CLYDE & WOOD, LLC///	100179	BOOE, RYANN	0	11/30/2022	11/30/2022	147.81
	CLYDE & WOOD, LLC///	100190	ELLER, MICHAEL	0	11/30/2022	11/30/2022	70.00
	CLYDE & WOOD, LLC///	100191	ELLER, MICHAEL	0	11/30/2022	11/30/2022	0.57
	CLYDE & WOOD, LLC///	100224	NICKEL, SCOTT	0	11/30/2022	11/30/2022	42.00
	CLYDE & WOOD, LLC///	100228	QUILLIN, STONE	0	11/30/2022	11/30/2022	70.57
	CLYDE & WOOD, LLC///	100235	TUCKER, DAWN	0	11/30/2022	11/30/2022	105.57
	CLYDE & WOOD, LLC///	100243	WILKES, JR., MICHAEL	0	11/30/2022	11/30/2022	133.81
	HARTLEY LAW GROUP LLC///	1148	WHISPELL, BRANDON	0	11/15/2022	11/30/2022	119.00
	HARTLEY LAW GROUP LLC///	1149	DONNELL, CHARLES	0	11/15/2022	11/30/2022	260.00
	HARTLEY LAW GROUP LLC///	1151	JOHNSON, JACQULYN	0	11/15/2022	11/30/2022	231.00
	HARTLEY LAW GROUP LLC///	1152	VANDERBUR, LAUREN	0	11/15/2022	11/30/2022	203.00
	HARTLEY LAW GROUP LLC///	1153	THOMPSON, AARON	0	11/15/2022	11/30/2022	238.00
	HARTLEY LAW GROUP LLC///	1154	BROOKS, BRAYDDEN	0	11/15/2022	11/30/2022	133.00
	HARTLEY LAW GROUP LLC///	1155	RILEY, CAMMIE	0	11/15/2022	11/30/2022	126.00
	TETWILER/LEE H.//	10695	OCTOBER CITY PROSECUTOR	71625	10/31/2022	11/30/2022	3,875.00
<b>Total Dept. MUNICIPAL COURT:</b>							<b>6,512.47</b>
01-004-700.271 PRISONER CARE							
	MIAMI COUNTY SHERIFF DEPT.		OCTOBER PRISONER CARE/MED	0	11/01/2022	11/30/2022	6,129.16
<b>Total Dept. MUNICIPAL COURT:</b>							<b>6,129.16</b>
01-004-700.300 GENERAL OFFICE SL							
	NAVRAT'S OFFICE PROD.-EMPC	0208173-001	CONCEALER	0	11/14/2022	11/30/2022	61.60
	NAVRAT'S OFFICE PROD.-EMPC	0208343-001	RECEIPT BOOK	0	11/22/2022	11/30/2022	39.62
<b>Total Dept. MUNICIPAL COURT:</b>							<b>101.22</b>
01-004-700.310 OPERATIONAL SUPP							
	GERKEN RENT-ALL///	22182/7	MOP, SNOW SHOVEL	0	11/16/2022	11/30/2022	98.44
<b>Total Dept. MUNICIPAL COURT:</b>							<b>98.44</b>
<b>Total Dept. MUNICIPAL COURT:</b>							<b>12,841.29</b>
<b>Dept: 005 STREET DEPARTMENT</b>							
01-005-700.230 TELEPHONE SERVIC							
	LIGHTHOUSE BIS, LLC PC-02///	CLD-1092454	NOVEMBER VOIP PHONE	0	11/30/2022	11/30/2022	116.42
	VERIZON///	9920094229	CELL PHONE PAYMENT	71617	11/09/2022	11/30/2022	79.45
<b>Total Dept. MUNICIPAL COURT:</b>							<b>195.87</b>
01-005-700.280 UTILITIES							
	EVERGY///		ELECTRIC BILL PAYMENTS	71609	11/14/2022	11/30/2022	52.26
	EVERGY///		ELECTRIC BILL PAYMENTS	71615	11/17/2022	11/30/2022	257.16
	EVERGY///		ELECTRIC BILL PAYMENTS	71615	11/17/2022	11/30/2022	32.03
	EVERGY///		ELECTRIC BILL PAYMENTS	71613	11/18/2022	11/30/2022	44.02
	EVERGY///		ELECTRIC BILL PAYMENTS	71613	11/18/2022	11/30/2022	29.10
	EVERGY///		ELECTRIC BILL PAYMENTS	71622	11/21/2022	11/30/2022	42.84
	EVERGY///		ELECTRIC BILL PAYMENTS	71622	11/21/2022	11/30/2022	57.09
	EVERGY///		ELECTRIC BILL PAYMENTS	71626	12/01/2022	11/30/2022	372.57
	KANSAS GAS SERVICE INC///		GAS BILL PAYMENTS	71610	11/14/2022	11/30/2022	44.80
<b>Total Dept. MUNICIPAL COURT:</b>							<b>931.87</b>
01-005-700.290 OTHER CONTRACTU							

**INVOICE APPROVAL LIST BY FUND REPORT**

APPR ORD #988 12/7/22

Date: 12/07/2022

Time: 4:58 pm

Page: 5

City of Paola

Fund/Dept/Acct	Vendor Name	Invoice #	Invoice Desc.	Check #	Due Date	Posting Date	Amount
	COPY PRODUCTS, INC///	32943514	COPIER CONTRACT/USAGE	0	12/01/2022	11/30/2022	28.72
	KSFIBERNET 0930000160///		DECEMBER INTERNET	0	12/01/2022	11/30/2022	50.00
	LIGHTHOUSE BIS, LLC PC-02///	RP-1092886	DECEMBER SECURITY	0	12/01/2022	11/30/2022	50.00
							<b>128.72</b>
01-005-700.310	OPERATIONAL SUPP						
	FAMILY CENTER INC///	4136477	2 - CHOP SAW BLADES	0	11/22/2022	11/30/2022	13.98
	FAMILY CENTER INC///	4141967	GRINDING DISC	0	12/02/2022	11/30/2022	11.45
	FASTENAL "MINNESOTA" INC///	KSOTT124887	40 - BAGS OF SALT	0	11/16/2022	11/30/2022	337.27
	GERKEN RENT-ALL, INC.///	513401-1	BLADES FOR CHIPPING HAMMER	0	11/17/2022	11/30/2022	163.50
	GERKEN RENT-ALL, INC.///	514541-1	BLADE	0	11/22/2022	11/30/2022	49.00
	GERKEN RENT-ALL///	22342/7	7" MASONRY BLADE	0	11/23/2022	11/30/2022	22.99
	MIAMI LUMBER INC///	2211-521317	CONCRETE MIX	0	11/17/2022	11/30/2022	16.86
	MIAMI LUMBER INC///	2211-521813	CUT OFF BLADE	0	11/23/2022	11/30/2022	5.99
	WALMART COMMUNITY INC///	11/18/22 02779	WATER, FILE FOLDERS, COFFEE	71621	11/18/2022	11/30/2022	12.93
							<b>633.97</b>
01-005-700.320	EQUIPMENT MAINTENANCE						
	AMERICAN EQUIPMENT CO INC	46193	8 - STROBE LIGHTS	0	11/15/2022	11/30/2022	308.42
	FAMILY CENTER INC///	4133202	AIR FILTER FOR CHOP SAW	0	11/17/2022	11/30/2022	18.99
	FAMILY CENTER INC///	4122533	RV ANTI-FREEZE #126	0	11/18/2022	11/30/2022	23.92
	GERKEN RENT-ALL///	22300/7	DIAMOND BLADE	0	11/21/2022	11/30/2022	24.99
	K.C. BOBCAT, INC///	19175370	FUEL FILTER #131	0	11/15/2022	11/30/2022	104.77
	KASPER AUTO PARTS, INC///	287089	HYDRAULIC FILTER #120	0	11/17/2022	11/30/2022	93.57
	KASPER AUTO PARTS, INC///	286901	LED LIGHT #118 & 119	0	11/15/2022	11/30/2022	35.49
	KASPER AUTO PARTS, INC///	286950	LED LIGHT RETURN	0	11/15/2022	11/30/2022	-35.49
	KASPER AUTO PARTS, INC///	287235	VALVE STEM EXTENSION #120	0	11/21/2022	11/30/2022	6.99
	KASPER AUTO PARTS, INC///	287802	TUBING & WIPER BLADE #123	0	12/02/2022	11/30/2022	10.57
	KASPER AUTO PARTS, INC///	287810	WASHER NOZZLE #123	0	12/02/2022	11/30/2022	22.99
	ROADBUILDERS MCH & SUP IN	P59631	WORK LIGHT & LAMP	0	11/21/2022	11/30/2022	485.99
	ROADBUILDERS MCH & SUP IN	P60092	LAMP RETURN	0	12/05/2022	11/30/2022	-183.87
							<b>917.33</b>
01-005-700.350	MOTOR FUEL & LUB						
	WEX BANK///	85597263	STREET DEPARTMENT	0	11/30/2022	11/30/2022	627.56
							<b>627.56</b>
01-005-700.370	UNIFORMS						
	UNIFIRST CORPORATION///	229 0102540	TOWELS & MATS	0	11/21/2022	11/30/2022	38.96
	UNIFIRST CORPORATION///	229 0102522	STREET DEPARTMENT	0	11/21/2022	11/30/2022	15.00
	UNIFIRST CORPORATION///	229 0105118	STREET DEPARTMENT	0	11/28/2022	11/30/2022	15.00
	UNIFIRST CORPORATION///	229 0105142	TOWELS & MATS	0	11/28/2022	11/30/2022	38.96
	UNIFIRST CORPORATION///	229 0107693	STREET DEPARTMENT	0	12/05/2022	11/30/2022	15.00
	UNIFIRST CORPORATION///	229 0107712	TOWELS & MATS	0	12/05/2022	11/30/2022	38.96
							<b>161.88</b>
01-005-700.390	MISCELLANEOUS						
	HAMM, INC///	488658	50.16 TON 3/4 SCREENING	0	11/22/2022	11/30/2022	271.35
							<b>271.35</b>
01-005-700.400	OFFICE EQUIP. FURN						
	VISA - 1348		.MAZON.COM*H01YS3NPO AMZ BATTERY FOR BACKUP	71612	10/25/2022	11/30/2022	17.99
							<b>17.99</b>
							<b>Total Dept. STREET DEPARTMENT: 3,886.54</b>
<b>Dept: 006 PARKS &amp; GROUNDS</b>							
01-006-700.230	TELEPHONE SERVICE						
	LIGHTHOUSE BIS, LLC PC-02///	CLD-1092454	NOVEMBER VOIP PHONE	0	11/30/2022	11/30/2022	47.26
	VERIZON///	9920094229	CELL PHONE PAYMENT	71617	11/09/2022	11/30/2022	126.53
							<b>173.79</b>
01-006-700.240	TRAINING, TRAVEL, I						
	KINAMAN/BRAD//		MEAL REIMBURSEMENT	0	11/30/2022	11/30/2022	16.49

**INVOICE APPROVAL LIST BY FUND REPORT**

APPR ORD #988 12/7/22

Date: 12/07/2022

Time: 4:58 pm

Page: 6

City of Paola

Fund/Dept/Acct	Vendor Name	Invoice #	Invoice Desc.	Check #	Due Date	Posting Date	Amount
VISA - 1348	/12 EB 2022 KANSAS TURF A 80		CHEMICAL APPLICATION	71612	10/12/2022	11/30/2022	134.24
							<b>150.73</b>
01-006-700.280	UTILITIES						
	EVERGY///		ELECTRIC BILL PAYMENTS	71609	11/14/2022	11/30/2022	58.16
	EVERGY///		ELECTRIC BILL PAYMENTS	71609	11/14/2022	11/30/2022	80.15
	EVERGY///		ELECTRIC BILL PAYMENTS	71609	11/14/2022	11/30/2022	40.50
	EVERGY///		ELECTRIC BILL PAYMENTS	71609	11/14/2022	11/30/2022	743.16
	EVERGY///		ELECTRIC BILL PAYMENTS	71615	11/17/2022	11/30/2022	151.57
	EVERGY///		ELECTRIC BILL PAYMENTS	71614	11/18/2022	11/30/2022	26.12
	EVERGY///		ELECTRIC BILL PAYMENTS	71614	11/18/2022	11/30/2022	27.24
	EVERGY///		ELECTRIC BILL PAYMENTS	71614	11/18/2022	11/30/2022	19.21
	EVERGY///		ELECTRIC BILL PAYMENTS	71614	11/18/2022	11/30/2022	113.59
	EVERGY///		ELECTRIC BILL PAYMENTS	71614	11/18/2022	11/30/2022	31.54
	EVERGY///		ELECTRIC BILL PAYMENTS	71614	11/18/2022	11/30/2022	83.66
	EVERGY///		ELECTRIC BILL PAYMENTS	71613	11/18/2022	11/30/2022	48.45
	EVERGY///		ELECTRIC BILL PAYMENTS	71613	11/18/2022	11/30/2022	18.17
	EVERGY///		ELECTRIC BILL PAYMENTS	71613	11/18/2022	11/30/2022	95.73
	EVERGY///		ELECTRIC BILL PAYMENTS	71622	11/21/2022	11/30/2022	19.88
	EVERGY///		ELECTRIC BILL PAYMENTS	71622	11/21/2022	11/30/2022	177.27
	EVERGY///		ELECTRIC BILL PAYMENTS	71622	11/21/2022	11/30/2022	18.14
	KANSAS GAS SERVICE INC///		GAS BILL PAYMENTS	71610	11/14/2022	11/30/2022	51.49
	KANSAS GAS SERVICE INC///		GAS BILL PAYMENTS	71610	11/14/2022	11/30/2022	44.80
							<b>1,848.83</b>
01-006-700.290	OTHER CONTRACTU						
	COPY PRODUCTS, INC///	32943514	COPIER CONTRACT/USAGE	0	12/01/2022	11/30/2022	28.73
	GERKEN RENT-ALL, INC.///	467686F-1	PORTABLE TOILET RENTAL - RED	0	11/25/2022	11/30/2022	100.00
	GERKEN RENT-ALL, INC.///	46027BV-1	PORTABLE TOILET RENTAL	0	12/02/2022	11/30/2022	78.00
	KSFIBERNET 0930000160///		DECEMBER INTERNET	0	12/01/2022	11/30/2022	50.00
	LIGHTHOUSE BIS, LLC PC-02///	RP-1092886	DECEMBER SECURITY	0	12/01/2022	11/30/2022	40.00
	VERIZON///	9920094229	CELL PHONE PAYMENT	71617	11/09/2022	11/30/2022	80.02
							<b>376.75</b>
01-006-700.295	TREE CARE						
	A & B TREE SERVICE	1807	TREE REMOVAL - 304 E. WEA,	0	11/04/2022	11/30/2022	1,650.00
							<b>1,650.00</b>
01-006-700.310	OPERATIONAL SUPP						
	FAMILY CENTER INC///	4132545	CHRISTMAS LIGHT WIRING	0	11/16/2022	11/30/2022	12.35
	FAMILY CENTER INC///	4132656	CHRISTMAS LIGHT WIRING	0	11/16/2022	11/30/2022	2.99
	FASTENAL "MINNESOTA" INC///	KSOTT124887	40 - BAGS OF SALT	0	11/16/2022	11/30/2022	337.27
	GERKEN RENT-ALL///	22193/7	GFI OUTLET & PLUG END FOR	0	11/16/2022	11/30/2022	100.45
	GERKEN RENT-ALL///	22398/7	WIRE STRIPPER	0	11/28/2022	11/30/2022	17.99
	GERKEN RENT-ALL///	22402/7	BOLTS & SCREWS TO FIX	0	11/28/2022	11/30/2022	4.50
	VISA - 1348	AMAZON.COM*H85YS9S02 AMZ	CHEMICAL INJECTOR	71612	10/27/2022	11/30/2022	40.75
	WALMART COMMUNITY INC///	11/16/22 02581	STAR FOR CHRISTMAS TREE	71621	11/16/2022	11/30/2022	4.88
	WALMART COMMUNITY INC///	11/18/22 02779	WATER, FILE FOLDERS, COFFEE	71621	11/18/2022	11/30/2022	12.92
							<b>534.10</b>
01-006-700.320	EQUIPMENT MAINTE						
	FAMILY CENTER INC///	4142030	TRAILER HITCH BALL	0	12/02/2022	11/30/2022	12.99
	VISA - 1348	3 AMZN MKTP US*HT81X4JX1 A	KUBOTA OIL FILLER CAP	71612	10/13/2022	11/30/2022	6.89
							<b>19.88</b>
01-006-700.350	MOTOR FUEL & LUB						
	WEX BANK///	85563131	PARKS DEPARTMENT	0	11/30/2022	11/30/2022	578.06
							<b>578.06</b>
01-006-700.370	UNIFORMS						
	UNIFIRST CORPORATION///	229 0102526	PARKS DEPARTMENT	0	11/21/2022	11/30/2022	12.93
	UNIFIRST CORPORATION///	229 0105122	PARKS DEPARTMENT	0	11/28/2022	11/30/2022	12.93
	UNIFIRST CORPORATION///	229 0107697	PARKS DEPARTMENT	0	12/05/2022	11/30/2022	12.93

**INVOICE APPROVAL LIST BY FUND REPORT**

APPR ORD #988 12/7/22

Date: 12/07/2022

Time: 4:58 pm

Page: 7

City of Paola

Fund/Dept/Acct	Vendor Name	Invoice #	Invoice Desc.	Check #	Due Date	Posting Date	Amount
							<b>38.79</b>
01-006-700.390	MISCELLANEOUS						
	HAMM, INC///	488658	50.16 TON 3/4 SCREENING	0	11/22/2022	11/30/2022	271.35
							<b>271.35</b>
							<b>Total Dept. PARKS &amp; GROUNDS: 5,642.28</b>
<b>Dept: 007 CEMETERY</b>							
01-007-700.350	MOTOR FUEL & LUB						
	WEX BANK///	85563132	CEMETERY DEPARTMENT	0	11/30/2022	11/30/2022	331.78
							<b>331.78</b>
01-007-700.370	UNIFORMS						
	UNIFIRST CORPORATION///	229 0102523	CEMETERY DEPARTMENT	0	11/21/2022	11/30/2022	4.31
	UNIFIRST CORPORATION///	229 0105119	CEMETERY DEPARTMENT	0	11/28/2022	11/30/2022	4.31
	UNIFIRST CORPORATION///	229 0107694	CEMETERY DEPARTMENT	0	12/05/2022	11/30/2022	4.31
							<b>12.93</b>
							<b>Total Dept. CEMETERY: 344.71</b>
<b>Dept: 009 COMMUNITY DEVELOPMEN</b>							
01-009-700.230	TELEPHONE SERVIC						
	LIGHTHOUSE BIS, LLC PC-02///	CLD-1092454	NOVEMBER VOIP PHONE	0	11/30/2022	11/30/2022	70.32
	VERIZON///	9920094229	CELL PHONE PAYMENT	71617	11/09/2022	11/30/2022	82.82
							<b>153.14</b>
01-009-700.290	OTHER CONTRACTU						
	BOYLE/JEFF//	244	602 N PEARL PLAN REVIEW	0	11/22/2022	11/30/2022	112.50
	BOYLE/JEFF//	245	CASEY'S RESUBMITTAL	0	11/23/2022	11/30/2022	225.00
	BOYLE/JEFF//	243	WALLACE PARK LIGHTS	0	11/17/2022	11/30/2022	150.00
	BOYLE/JEFF//	246	PLAN REVIEW & RESUBMITTAL	0	11/29/2022	11/30/2022	375.00
	GFI DIGITAL///	2397369	COPIER USAGE CHARGE	0	11/23/2022	11/30/2022	20.72
	LIGHTHOUSE BIS, LLC PC-02///	RP-1092886	DECEMBER SECURITY	0	12/01/2022	11/30/2022	30.00
	VERIZON///	9920094229	CELL PHONE PAYMENT	71617	11/09/2022	11/30/2022	80.02
							<b>993.24</b>
01-009-700.300	GENERAL OFFICE SL						
	VISA - 1348		AMZN MKTP US*H89HO3ZU1 A NAME PLATES	71612	10/20/2022	11/30/2022	15.11
							<b>15.11</b>
01-009-700.315	VEHICLE MAINTENAN						
	THE CAR POOL	10	2 CAR WASHES SEPTEMBER	0	12/04/2022	11/30/2022	19.20
							<b>19.20</b>
01-009-700.350	MOTOR FUEL & LUB						
	WEX BANK///	85570927	COMMUNITY DEVELOPMENT	0	11/30/2022	11/30/2022	186.05
							<b>186.05</b>
							<b>Total Dept. COMMUNITY DEVELOPMENT: 1,366.74</b>
							<b>Fund GENERAL OPERATING: 73,396.73</b>
<b>Fund: 02 LIBRARY</b>							
<b>Dept: 022 LIBRARY</b>							
02-022-700.230	TELEPHONE SERVIC						
	LIGHTHOUSE BIS, LLC PC-02///	CLD-1092454	NOVEMBER VOIP PHONE	0	11/30/2022	11/30/2022	128.06
							<b>128.06</b>
02-022-700.240	TRAINING, TRAVEL, I						

**INVOICE APPROVAL LIST BY FUND REPORT**

APPR ORD #988 12/7/22

Date: 12/07/2022

Time: 4:58 pm

Page: 8

City of Paola

Fund/Dept/Acct	Vendor Name	Invoice #	Invoice Desc.	Check #	Due Date	Posting Date	Amount
	BUSINESS CARD - 7149	0 DILLONS #0019	LAWRENCE K IN-SERVICE BREAKFAST/	71620	10/09/2022	11/30/2022	27.31
	BUSINESS CARD - 7149	1/11 SQ	*DAYLIGHT DONUT PAO IN-SERVICE BREAKFAST/	71620	10/10/2022	11/30/2022	45.86
	BUSINESS CARD - 7149	10/11	CKE*SPUDLEYS PAOLA IN-SERVICE LUNCH FOR STAFF	71620	10/10/2022	11/30/2022	46.82
	BUSINESS CARD - 7149	10/27	KWIK SHOP #0786 FUEL FOR KLA TRIP	71620	10/26/2022	11/30/2022	19.01
	BUSINESS CARD - 7149	27	TST* NORTONS BREWING C KLA DINNER	71620	10/27/2022	11/30/2022	27.56
	BUSINESS CARD - 7149	10/31	QT 326 WICHITA KS FUEL FOR KLA TRIP	71620	10/27/2022	11/30/2022	17.71
							<b>184.27</b>
02-022-700.255	ADVERTISING EXPEN						
	BUSINESS CARD - 7149	10/21	FACEBK *KF8J5GTQ62	71620	10/20/2022	11/30/2022	14.39
							<b>14.39</b>
02-022-700.280	UTILITIES						
	EVERGY///		ELECTRIC BILL PAYMENTS	71615	11/17/2022	11/30/2022	668.43
	KANSAS GAS SERVICE INC///		GAS BILL PAYMENTS	71610	11/14/2022	11/30/2022	32.38
	WASTE MGMT OF KS INC - 4856	0573487-4856-7	101 E PEORIA - 96 GALLON	0	11/16/2022	11/30/2022	36.00
							<b>736.81</b>
02-022-700.290	OTHER CONTRACTU						
	ALL COPY PRODUCTS - 660831/	32865027	COPIER CONTRACT/USAGE	0	11/18/2022	11/30/2022	261.40
	KSFIBERNET 0930000153///		DECEMBER INTERNET	0	12/01/2022	11/30/2022	90.00
	LIGHTHOUSE BIS, LLC PC-02///	RP-1092886	DECEMBER SECURITY	0	12/01/2022	11/30/2022	15.00
	LIGHTHOUSE BIS, LLC PFL-01///	CLD-1092384	NOVEMBER CLOUD BACKUP	0	11/30/2022	11/30/2022	109.00
							<b>475.40</b>
02-022-700.301	POSTAGE						
	BUSINESS CARD - 7149	10/14	USPS PO 1970070591	71620	10/13/2022	11/30/2022	6.55
	BUSINESS CARD - 7149	20	USPS PO 1970070591 PAOLA	71620	10/19/2022	11/30/2022	60.00
	BUSINESS CARD - 7149	1/24	USPS PO 1970070591 PAO	71620	10/21/2022	11/30/2022	3.95
							<b>70.50</b>
02-022-700.330	BUILDING & MAINTEN						
	BUSINESS CARD - 7149	10/14	FAMILY CTR OF PAOLA	71620	10/14/2022	11/30/2022	69.89
	P.Q.L., INC///	40531691-01	6-12 YEAR LIGHTBULBS	0	11/14/2022	11/30/2022	262.77
	SUFFRON GLASS CO. INC///		DOOR ADJUSTMENT	0	11/29/2022	11/30/2022	103.79
							<b>436.45</b>
02-022-700.344	LIBRARY MEDIA - GE						
	BAKER & TAYLOR BOOKS INC.//	2037138663	BOOKS & JACKETS	0	11/15/2022	11/30/2022	213.68
	BAKER & TAYLOR BOOKS INC.//	2037154036	BOOKS & JACKETS	0	11/18/2022	11/30/2022	98.29
	BAKER & TAYLOR BOOKS INC.//	0003273884	CREDIT FOR BOOK	0	11/14/2022	11/30/2022	-17.42
	BLACKSTONE PUBLISHING///	2075430	BOOKS ON CD'S	0	11/23/2022	11/30/2022	104.84
	COFER/DERECK E//	1691484	LOST ITEM FEE REFUND	0	11/07/2022	11/30/2022	25.00
	GALE-CENGAGE LEARNING INC	79663784	NOVEMBER MYSTERY 2 PLAN	0	11/16/2022	11/30/2022	53.98
	GALE-CENGAGE LEARNING INC	79663810	NOVEMBER BESTSELLER	0	11/16/2022	11/30/2022	61.58
	GALE-CENGAGE LEARNING INC	79663765	NOVEMBER BESTSELLER	0	11/16/2022	11/30/2022	61.58
							<b>601.53</b>
02-022-700.345	LIBRARY MATERIALS						
	BRODART CO.	613872	DISC CASE & BOOK REPAIR	0	11/14/2022	11/30/2022	71.46
	DEMCO INC///	7219815	BOOK REPAIR SUPPLIES	0	11/15/2022	11/30/2022	87.78
							<b>159.24</b>
02-022-700.347	ADULT PROGRAMMIN						
	BUSINESS CARD - 7149	10/10	PARTY CITY.COM	71620	10/08/2022	11/30/2022	63.36
							<b>63.36</b>
02-022-700.402	COMPUTER EQUIP / :						
	ELM USA INC///	53358	ECO PRO PRO-KIT DISC REPAIR	0	10/21/2022	11/30/2022	100.99
	LIGHTHOUSE BIS, LLC PFL-01///	011755	ALTIGEN SOFTWARE ASSURANCE	0	11/21/2022	11/30/2022	525.00
	R.K. BLACK, INC///	IN980719	CHARGE	71618	09/30/2022	11/30/2022	14.47
							<b>640.46</b>
							<b>Total Dept. LIBRARY: 3,510.47</b>

**INVOICE APPROVAL LIST BY FUND REPORT**

APPR ORD #988 12/7/22

Date: 12/07/2022

Time: 4:58 pm

Page: 9

City of Paola

Fund/Dept/Acct	Vendor Name	Invoice #	Invoice Desc.	Check #	Due Date	Posting Date	Amount
<b>Total Fund LIBRARY:</b>							<b>3,510.47</b>
<b>Fund: 04 SEWER SERVICE</b>							
<b>Dept: 001 ADMINISTRATION</b>							
04-001-700.230	TELEPHONE SERVIC LIGHTHOUSE BIS, LLC PC-02///	CLD-1092454	NOVEMBER VOIP PHONE	0	11/30/2022	11/30/2022	47.26
							<b>47.26</b>
04-001-700.290	OTHER CONTRACTU LIGHTHOUSE BIS, LLC PC-02///	RP-1092886	DECEMBER SECURITY	0	12/01/2022	11/30/2022	10.00
							<b>10.00</b>
04-001-700.301	POSTAGE PITNEY BOWES INC 223648 RE: U.S. POSTMASTER///	#4 11/17/2022	POSTAGE UTILITY BILL MAILING	0 71624	11/17/2022 11/30/2022	11/30/2022 11/30/2022	333.33 302.63
							<b>635.96</b>
<b>Total Dept. ADMINISTRATION:</b>							<b>693.22</b>
<b>Dept: 032 PRODUCTION</b>							
04-032-700.230	TELEPHONE SERVIC VERIZON///	9920094229	CELL PHONE PAYMENT	71617	11/09/2022	11/30/2022	84.11
							<b>84.11</b>
04-032-700.280	UTILITIES EVERGY/// KANSAS GAS SERVICE INC/// RURAL WATER DIST NO. 2 INC//		ELECTRIC BILL PAYMENTS GAS BILL PAYMENTS WATER USAGE 200 GALLONS	71614 71610 0	11/18/2022 11/14/2022 11/29/2022	11/30/2022 11/30/2022 11/30/2022	1,414.04 34.30 22.01
							<b>1,470.35</b>
04-032-700.350	MOTOR FUEL & LUB WEX BANK///	85555374	SEWER DEPARTMENT	0	11/30/2022	11/30/2022	105.01
							<b>105.01</b>
04-032-700.370	UNIFORMS UNIFIRST CORPORATION/// UNIFIRST CORPORATION/// UNIFIRST CORPORATION///	229 0102524 229 0105120 229 0107695	SEWER DEPARTMENT SEWER DEPARTMENT SEWER DEPARTMENT	0 0 0	11/21/2022 11/28/2022 12/05/2022	11/30/2022 11/30/2022 11/30/2022	4.31 4.31 4.31
							<b>12.93</b>
<b>Total Dept. PRODUCTION:</b>							<b>1,672.40</b>
<b>Dept: 033 DISTRIBUTION (LINES)</b>							
04-033-700.230	TELEPHONE SERVIC VERIZON///	9920094229	CELL PHONE PAYMENT	71617	11/09/2022	11/30/2022	34.51
							<b>34.51</b>
04-033-700.240	TRAINING, TRAVEL, [ ] VISA - 1348	/18 KTA VIDEO TOLL WICHITA K	TURNPIKE COST	71612	10/18/2022	11/30/2022	5.75
							<b>5.75</b>
04-033-700.280	UTILITIES EVERGY/// EVERGY/// EVERGY/// EVERGY/// EVERGY/// EVERGY/// KANSAS GAS SERVICE INC///		ELECTRIC BILL PAYMENTS ELECTRIC BILL PAYMENTS ELECTRIC BILL PAYMENTS ELECTRIC BILL PAYMENTS ELECTRIC BILL PAYMENTS ELECTRIC BILL PAYMENTS GAS BILL PAYMENTS	71609 71609 71615 71615 71615 71615 71610	11/14/2022 11/14/2022 11/17/2022 11/17/2022 11/17/2022 11/17/2022 11/14/2022	11/30/2022 11/30/2022 11/30/2022 11/30/2022 11/30/2022 11/30/2022 11/30/2022	20.72 30.15 44.04 54.88 178.71 21.97 44.80
							<b>395.27</b>
04-033-700.290	OTHER CONTRACTU COPY PRODUCTS, INC/// KANSAS ONE-CALL SYSTEM IN	32943514 2110422	COPIER CONTRACT/USAGE 103 LOCATES	0 0	12/01/2022 11/30/2022	11/30/2022 11/30/2022	28.73 61.80

**INVOICE APPROVAL LIST BY FUND REPORT**

APPR ORD #988 12/7/22

Date: 12/07/2022

Time: 4:58 pm

Page: 10

City of Paola

Fund/Dept/Acct	Vendor Name	Invoice #	Invoice Desc.	Check #	Due Date	Posting Date	Amount
	KSFIBERNET 0930000160///		DECEMBER INTERNET	0	12/01/2022	11/30/2022	50.00
							<b>140.53</b>
04-033-700.310	OPERATIONAL SUPP						
	GERKEN RENT-ALL///	22139/7	CERAMIC HEATER FOR	0	11/14/2022	11/30/2022	32.99
	HAMM, INC///	488658	50.16 TON 3/4 SCREENING	0	11/22/2022	11/30/2022	271.35
	OLATHE WINWATER WORKS IN	177795 00	CLAMPS, HYMAX COUPLINGS	0	11/29/2022	11/30/2022	1,008.00
	VISA - 1348	AMZN MKTP US*H05DN2W10 A	BODY SAFETY HARNESS	71612	10/31/2022	11/30/2022	42.80
	VISA - 1348	HOMEDEPOT.COM 800-430-33	27 PIECE AIR TOOL KIT	71612	10/20/2022	11/30/2022	119.00
	WALMART COMMUNITY INC///	11/18/22 02779	WATER, FILE FOLDERS, COFFEE	71621	11/18/2022	11/30/2022	12.93
							<b>1,487.07</b>
04-033-700.320	EQUIPMENT MAINTE						
	K.C. BOBCAT, INC///	19175781	TOOTH TIP/RUBBER FLEX PIN	0	11/29/2022	11/30/2022	147.34
	RED EQUIPMENT, LLC	2703	FILTER ELEMENTS #405	0	11/11/2022	11/30/2022	345.38
	RED EQUIPMENT, LLC	2687	SWITCH BANK 4	0	11/01/2022	11/30/2022	267.73
	VISA - 1348	0/10 GRAINGER 877-2022594 IL	BOLT FOR FLANGES	71612	10/10/2022	11/30/2022	20.94
							<b>781.39</b>
04-033-700.350	MOTOR FUEL & LUB						
	WEX BANK///	85584687	SEWER DEPARTMENT	0	11/30/2022	11/30/2022	968.43
							<b>968.43</b>
04-033-700.370	UNIFORMS						
	UNIFIRST CORPORATION///	229 0102524	SEWER DEPARTMENT	0	11/21/2022	11/30/2022	9.06
	UNIFIRST CORPORATION///	229 0105120	SEWER DEPARTMENT	0	11/28/2022	11/30/2022	9.06
	UNIFIRST CORPORATION///	229 0107695	SEWER DEPARTMENT	0	12/05/2022	11/30/2022	9.06
							<b>27.18</b>
04-033-700.420	EQUIP/BLDG & GROU						
	WTP EQUIPMENT CORP///	1020-23	DRIVE SHAFT	0	11/28/2022	11/30/2022	928.00
							<b>928.00</b>
04-033-700.430	MOTOR VEHICLE/EQ						
	VISA - 1348	13 MIAMI CO MOTOR VEHICLES	LICENSE PLATE FOR 2022 FORD	71612	10/13/2022	11/30/2022	31.25
	VISA - 1348	13 EGOV SERVICE FEE 877-634	MIAMI COUNTY MOTOR VEHICLE	71612	10/13/2022	11/30/2022	0.78
							<b>32.03</b>
							<b>Total Dept. DISTRIBUTION (LINES): 4,800.16</b>
							<b>Total Fund SEWER SERVICE: 7,165.78</b>
<b>Fund: 05 EMPLOYEE BENEFIT</b>							
<b>Dept: 000</b>							
05-000-700.139	HRA PREMIUMS						
	SURENCY LIFE & HEALTH///		DECEMBER HRA, COBRA, FSA	0	12/01/2022	11/30/2022	300.00
							<b>300.00</b>
05-000-700.140	HEALTH INSURANCE						
	BLUE CROSS & BLUE SHIELD	16638880	DECEMBER HEALTH INSURANCE	71608	11/12/2022	11/30/2022	21,097.67
							<b>21,097.67</b>
05-000-700.141	COBRA INSURANCE						
	BLUE CROSS & BLUE SHIELD	16638880	DECEMBER HEALTH INSURANCE	71608	11/12/2022	11/30/2022	832.95
							<b>832.95</b>
							<b>Total Dept. 000: 22,230.62</b>
							<b>Total Fund EMPLOYEE BENEFIT: 22,230.62</b>
<b>Fund: 07 FAMILY AQUATICS CENTER</b>							
<b>Dept: 000</b>							
07-000-700.230	TELEPHONE SERVIC						
	LIGHTHOUSE BIS, LLC PC-02///	CLD-1092454	NOVEMBER VOIP PHONE	0	11/30/2022	11/30/2022	58.79



**INVOICE APPROVAL LIST BY FUND REPORT**

APPR ORD #988 12/7/22

Date: 12/07/2022

Time: 4:58 pm

Page: 11

City of Paola

Fund/Dept/Acct	Vendor Name	Invoice #	Invoice Desc.	Check #	Due Date	Posting Date	Amount
							<b>58.79</b>
07-000-700.280	UTILITIES						
	EVERGY///		ELECTRIC BILL PAYMENTS	71622	11/21/2022	11/30/2022	324.19
	KANSAS GAS SERVICE INC///		GAS BILL PAYMENTS	71610	11/14/2022	11/30/2022	52.88
							<b>377.07</b>
07-000-700.290	OTHER CONTRACTU						
	KSFIBERNET 0930000160///		DECEMBER INTERNET	0	12/01/2022	11/30/2022	100.00
							<b>100.00</b>
07-000-700.410	EQUIPMENT/PLANT						
	WALMART COMMUNITY INC///	12/06/22 04311	COMPUTER FOR POOL PASSES	0	12/06/2022	11/30/2022	129.00
							<b>129.00</b>
							<b>Total Dept. 000: 664.86</b>
							<b>! FAMILY AQUATICS CENTER: 664.86</b>
<b>Fund: 08 COMMUNITY CENTER</b>							
<b>Dept: 000</b>							
08-000-700.230	TELEPHONE SERVIC						
	LIGHTHOUSE BIS, LLC PC-02///	CLD-1092454	NOVEMBER VOIP PHONE	0	11/30/2022	11/30/2022	47.26
	VERIZON///	9920094229	CELL PHONE PAYMENT	71617	11/09/2022	11/30/2022	41.41
							<b>88.67</b>
08-000-700.280	UTILITIES						
	EVERGY///		ELECTRIC BILL PAYMENTS	71622	11/21/2022	11/30/2022	670.72
	KANSAS GAS SERVICE INC///		GAS BILL PAYMENTS	71610	11/14/2022	11/30/2022	86.98
							<b>757.70</b>
08-000-700.290	OTHER CONTRACTU						
	KSFIBERNET 0930000160///		DECEMBER INTERNET	0	12/01/2022	11/30/2022	100.00
	LIGHTHOUSE BIS, LLC PC-02///	RP-1092886	DECEMBER SECURITY	0	12/01/2022	11/30/2022	10.00
	SMITH & SONS, INC./G.K./	00356320000	REPLACED BLOWER MOTOR	0	10/22/2022	11/30/2022	802.27
							<b>912.27</b>
08-000-700.310	OPERATIONAL SUPP						
	GERKEN RENT-ALL///	22158/7	FLUORESCENT BULBS	0	11/14/2022	11/30/2022	43.16
	GERKEN RENT-ALL///	22159/7	BULB RETURN	0	11/14/2022	11/30/2022	-43.17
	GERKEN RENT-ALL///	22523/7	TRASH BAGS, PAPER TOWELS	0	12/05/2022	11/30/2022	56.97
							<b>56.96</b>
08-000-700.330	BUILDING & MAINTEN						
	OTIS ELEVATOR COMPANY INC,	100400983563	DECEMBER MAINTENANCE	0	11/14/2022	11/30/2022	131.06
	OTIS ELEVATOR COMPANY INC,	100400953722	NOVEMBER ELEVATOR	0	10/17/2022	11/30/2022	126.89
							<b>257.95</b>
08-000-700.795	REAL ESTATE TAXES						
	MIAMI COUNTY TREASURER///	22473	RENTAL ROOM OFFICE	0	11/05/2022	11/30/2022	205.22
	MIAMI COUNTY TREASURER///	22470	RENTAL ROOM OFFICE 209	0	11/05/2022	11/30/2022	205.22
							<b>410.44</b>
							<b>Total Dept. 000: 2,483.99</b>
							<b>! Fund COMMUNITY CENTER: 2,483.99</b>

**Fund: 09 WATER UTILITY**  
**Dept: 001 ADMINISTRATION**

09-001-700.230	TELEPHONE SERVIC						
	LIGHTHOUSE BIS, LLC PC-02///	CLD-1092454	NOVEMBER VOIP PHONE	0	11/30/2022	11/30/2022	47.26
							<b>47.26</b>

09-001-700.290 OTHER CONTRACTU

**INVOICE APPROVAL LIST BY FUND REPORT**

APPR ORD #988 12/7/22

Date: 12/07/2022

Time: 4:58 pm

Page: 12

City of Paola

Fund/Dept/Acct	Vendor Name	Invoice #	Invoice Desc.	Check #	Due Date	Posting Date	Amount
	LIGHTHOUSE BIS, LLC PC-02///	RP-1092886	DECEMBER SECURITY	0	12/01/2022	11/30/2022	20.00
	U.S. POSTMASTER///		2022 RENT FOR PO BOX 409	0	12/05/2022	11/30/2022	218.00
							<b>238.00</b>
09-001-700.301	POSTAGE						
	PITNEY BOWES INC 223648 RE	#4 11/17/2022	POSTAGE	0	11/17/2022	11/30/2022	333.33
	U.S. POSTMASTER///		UTILITY BILL MAILING	71624	11/30/2022	11/30/2022	302.63
							<b>635.96</b>
							<b>Total Dept. ADMINISTRATION: 921.22</b>
<b>Dept: 032 PRODUCTION</b>							
09-032-700.240	TRAINING, TRAVEL, [						
	VISA - 1348	AMERICAN WATER WORKS ASS	AMERICAN WATER WORKS	71612	10/21/2022	11/30/2022	174.00
							<b>174.00</b>
09-032-700.280	UTILITIES						
	EVERGY///		ELECTRIC BILL PAYMENTS	71609	11/14/2022	11/30/2022	114.73
	EVERGY///		ELECTRIC BILL PAYMENTS	71609	11/14/2022	11/30/2022	25.05
	EVERGY///		ELECTRIC BILL PAYMENTS	71609	11/14/2022	11/30/2022	66.89
	EVERGY///		ELECTRIC BILL PAYMENTS	71615	11/17/2022	11/30/2022	20.09
	EVERGY///		ELECTRIC BILL PAYMENTS	71614	11/18/2022	11/30/2022	63.66
	EVERGY///		ELECTRIC BILL PAYMENTS	71613	11/18/2022	11/30/2022	114.12
	EVERGY///		ELECTRIC BILL PAYMENTS	71613	11/18/2022	11/30/2022	198.43
							<b>602.97</b>
							<b>Total Dept. PRODUCTION: 776.97</b>
<b>Dept: 033 DISTRIBUTION (LINES)</b>							
09-033-700.230	TELEPHONE SERVIC						
	VERIZON///	9920094229	CELL PHONE PAYMENT	71617	11/09/2022	11/30/2022	58.35
							<b>58.35</b>
09-033-700.240	TRAINING, TRAVEL, [						
	VISA - 1348	AMERICAN WATER WORKS ASS	AMERICAN WATER WORKS	71612	10/21/2022	11/30/2022	174.00
							<b>174.00</b>
09-033-700.280	UTILITIES						
	KANSAS GAS SERVICE INC///		GAS BILL PAYMENTS	71610	11/14/2022	11/30/2022	44.80
	RURAL WATER DIST NO. 2 INC//		WATER USAGE 1,760 GALLONS	0	11/29/2022	11/30/2022	25.86
							<b>70.66</b>
09-033-700.290	OTHER CONTRACTU						
	COPY PRODUCTS, INC///	32943514	COPIER CONTRACT/USAGE	0	12/01/2022	11/30/2022	28.73
	KANSAS ONE-CALL SYSTEM IN	2110422	103 LOCATES	0	11/30/2022	11/30/2022	61.80
	KSFIBERNET 0930000160///		DECEMBER INTERNET	0	12/01/2022	11/30/2022	50.00
	RAILROAD MGMN CO///	471474	WATER PIPELINE CROSSING	0	11/30/2022	11/30/2022	344.67
							<b>485.20</b>
09-033-700.310	OPERATIONAL SUPP						
	CORE & MAIN LP///	R972929	10 - 5/8" WATER METERS	0	11/21/2022	11/30/2022	743.10
	FAMILY CENTER INC///	4139907	MARKING PAINT, TRANSPLANTER	0	11/28/2022	11/30/2022	28.88
	GERKEN RENT-ALL, INC.///	513401-1	BLADES FOR CHIPPING HAMMER	0	11/17/2022	11/30/2022	163.50
	GERKEN RENT-ALL, INC.///	516766-1	3 - BITS	0	12/05/2022	11/30/2022	124.00
	GERKEN RENT-ALL, INC.///	516781-1	1" HAMMER DRILL BIT	0	12/05/2022	11/30/2022	39.95
	GERKEN RENT-ALL///	22189/7	TORCH BLADE & SAWZALL	0	11/16/2022	11/30/2022	46.98
	HAMM, INC///	488658	50.16 TON 3/4 SCREENING	0	11/22/2022	11/30/2022	271.35
	OLATHE WINWATER WORKS IN	176764 04	4 - PIPE REPAIR CLAMPS	0	11/18/2022	11/30/2022	1,300.00
	OLATHE WINWATER WORKS IN	177795 02	POTABLE WATER TUBING	0	11/30/2022	11/30/2022	165.00
	OLATHE WINWATER WORKS IN	177795 00	CLAMPS, HYMAX COUPLINGS	0	11/29/2022	11/30/2022	3,215.00
	VISA - 1348	20 SIMPLE SIMONS PIZZA PAOL	MEAL	71612	10/20/2022	11/30/2022	41.48
	WALMART COMMUNITY INC///	11/18/22 02779	WATER, FILE FOLDERS, COFFEE	71621	11/18/2022	11/30/2022	12.92
							<b>6,152.16</b>

**INVOICE APPROVAL LIST BY FUND REPORT**

APPR ORD #988 12/7/22

Date: 12/07/2022

Time: 4:58 pm

Page: 13

City of Paola

Fund/Dept/Acct	Vendor Name	Invoice #	Invoice Desc.	Check #	Due Date	Posting Date	Amount
09-033-700.315	VEHICLE MAINTENAN						
	KASPER AUTO PARTS, INC///	287547	BRAKE SHOES #503	0	11/28/2022	11/30/2022	56.99
	KASPER AUTO PARTS, INC///	287534	OIL & FILTER #503	0	11/28/2022	11/30/2022	29.23
	O'REILLY AUTO PARTS INC///	0205-300309	BRAKE HARDWARE #503	0	11/28/2022	11/30/2022	23.86
	O'REILLY AUTO PARTS INC///	0205-300310	BRAKE HARDWARE RETURN	0	11/28/2022	11/30/2022	-11.93
							<b>98.15</b>
09-033-700.320	EQUIPMENT MAINTEN						
	KASPER AUTO PARTS, INC///	286949	OIL FILTER #405	0	11/15/2022	11/30/2022	22.40
							<b>22.40</b>
09-033-700.350	MOTOR FUEL & LUB						
	WEX BANK///	85555373	WATER DEPARTMENT	0	11/30/2022	11/30/2022	580.47
							<b>580.47</b>
09-033-700.370	UNIFORMS						
	UNIFIRST CORPORATION///	229 0102525	WATER DEPARTMENT	0	11/21/2022	11/30/2022	8.62
	UNIFIRST CORPORATION///	229 0105121	WATER DEPARTMENT	0	11/28/2022	11/30/2022	8.62
	UNIFIRST CORPORATION///	229 0107696	WATER DEPARTMENT	0	12/05/2022	11/30/2022	8.62
							<b>25.86</b>
							<b>Total Dept. DISTRIBUTION (LINES): 7,667.25</b>
							<b>Total Fund WATER UTILITY: 9,365.44</b>

**Fund: 12 STORM WATER MANAGEMEN**

**Dept: 033 DISTRIBUTION (LINES)**

12-033-700.460	STORM WATER CON						
	HAMM, INC///	488065	83.09 TON 18" RIP RAP	0	11/18/2022	11/30/2022	2,816.03
							<b>2,816.03</b>
							<b>Total Dept. DISTRIBUTION (LINES): 2,816.03</b>
							<b>FORM WATER MANAGEMENT: 2,816.03</b>

**Fund: 26 COVID ACCOUNT**

**Dept: 000**

26-000-700.340	CONSTRUCTION MA						
	OLATHE WINWATER WORKS INC	176764 02	HYMAX COUPLINGS & SS	0	11/04/2022	11/30/2022	2,150.00
							<b>2,150.00</b>
							<b>Total Dept. 000: 2,150.00</b>
							<b>Total Fund COVID ACCOUNT: 2,150.00</b>

**Fund: 27 SALES TAX PROJECTS 2022**

**Dept: 000**

27-000-700.290	OTHER CONTRACTU						
	MAMMOTH SPORTS CONST, LL	2	WALLACE PARK PHASE #1	0	11/21/2022	11/30/2022	807,714.60
							<b>807,714.60</b>
							<b>Total Dept. 000: 807,714.60</b>
							<b>SALES TAX PROJECTS 2022: 807,714.60</b>

**Fund: 70 SPECIAL GRANTS**

**Dept: 701 LIBRARY - BAHER GRANT**

70-701-700.345	LIBRARY MATERIALS						
	BUSINESS CARD - 7149 0/31	HYATT REGENCY WICHITA	KLA HOTEL ROOM	71620	10/27/2022	11/30/2022	177.87
	BUSINESS CARD - 7149 0/14	SCHOLASTIC EDUCATION	KS READS TO PRESCHOOLERS	71620	10/13/2022	11/30/2022	101.70
	BUSINESS CARD - 7149 0/28	FUN EXPRESS OMAHA NE	CHILDREN'S PROGRAM SUPPLIES	71620	10/26/2022	11/30/2022	181.38
	VERIZON - LIBRARY	9920117414	MOBILE BROADBAND CHARGES	71619	11/09/2022	11/30/2022	1,120.32

**INVOICE APPROVAL LIST BY FUND REPORT**

APPR ORD #988 12/7/22

Date: 12/07/2022

Time: 4:58 pm

Page: 14

City of Paola

Fund/Dept/Acct	Vendor Name	Invoice #	Invoice Desc.	Check #	Due Date	Posting Date	Amount
	WALMART COMMUNITY INC///	11/18/22 02797	CARD	71621	11/18/2022	11/30/2022	3.98
	WALMART COMMUNITY INC///	11/29/22 03860	FABRIC, GINGERBREAD	0	11/29/2022	11/30/2022	136.08
							<b>1,721.33</b>
							<b>Total Dept. LIBRARY - BAHER GRANT: 1,721.33</b>
							<b>Total Fund SPECIAL GRANTS: 1,721.33</b>
<b>Fund: 90 CIP - CAPITAL IMPROVEMEN</b>							
<b>Dept: 305 CIP - STREETS PROGRAM</b>							
90-305-700.340	CONSTRUCTION MAT						
	GERKEN RENT-ALL, INC.///	516188-1	CONCRETE DELIVERY	0	12/02/2022	11/30/2022	387.50
	WILSON/BRADLEY J.//	11-A51	CONCRETE WORK	0	11/22/2022	11/30/2022	22,972.00
							<b>23,359.50</b>
							<b>Total Dept. CIP - STREETS PROGRAM: 23,359.50</b>
<b>Dept: 316 CIP - FIRE DEPT BUILDING</b>							
90-316-700.265	LEASE PAYMENTS						
	FIRST OPTION BANK INC///		FIRE TRUCK PAYMENT	0	11/30/2022	11/30/2022	58,997.50
							<b>58,997.50</b>
							<b>Total Dept. CIP - FIRE DEPT BUILDING: 58,997.50</b>
<b>Dept: 320 CIP - PAOLA PATHWAYS TR.</b>							
90-320-700.340	CONSTRUCTION MAT						
	HAMM, INC///	488273	42.67 TON SCREENINGS FOR	0	11/21/2022	11/30/2022	506.02
							<b>506.02</b>
<b>90-320-700.390 MISCELLANEOUS</b>							
	VISA - 1348		SQUARESPACE INC. HTTPSSQ	71612	10/28/2022	11/30/2022	6.00
			PATHWAYS E-MAIL CHARGE				<b>6.00</b>
							<b>512.02</b>
							<b>Total Dept. CIP - PAOLA PATHWAYS TRAILS: 512.02</b>
							<b>CAPITAL IMPROVEMENT PROJ: 82,869.02</b>
							<b>Grand Total: 1,016,088.87</b>



**Paola City Council  
Pledge Collateral Analysis**

**Consent Agenda Item 1-d**

DATE: 11/30/2022

<b><u>Bank</u></b>	<b><u>Demand Deposits</u></b>	<b><u>CDs on Deposit</u></b>	<b><u>Pledged Collateral</u></b>	<b><u>FDIC Insurance</u></b>	<b><u>Overage (Shortage)</u></b>
Security Bank of KC	\$5,749,335.08	\$0.00	\$9,428,664.04	\$250,000.00	\$3,929,328.96
First Option Bank	\$728,638.00	\$4,000,000.00	\$5,523,908.00	\$250,000.00	\$1,045,270.00
Great Southern Bank	\$0.00	\$0.00	\$0.00	\$0.00	\$0.00
Landmark National Bank	\$0.00	\$0.00	\$0.00	\$0.00	\$0.00
<u>First Security Bank</u>	<u>\$0.00</u>	<u>\$250,000.00</u>	<u>\$0.00</u>	<u>\$250,000.00</u>	<u>\$0.00</u>
Totals	\$6,477,973.08	\$4,250,000.00	\$14,952,572.04	\$750,000.00	\$4,974,598.96

**JOURNAL ENTRIES**  
MANUAL JOURNALS 11/22

Page: 1  
12/8/2022  
3:45 pm

City of Paola

JE #	Entry Date User Name	Posting Date JE Code	Type	Description 1 Description 2 GL #	Description 3 Source Line Distribution Description	Source Desc Debit Amount	Credit Amount
1	11/30/2022 SUPER	11/30/2022 Manual	GJ	CHECKING ACCOUNT INTEREST			
				01-000-400.230	SECURITY	0.00	236.99
				01-000-400.230	FIRST OPTION MMKT	0.00	573.73
				01-000-400.230	FIRST OPTION PAYROLL	0.00	184.92
				01-000-001.000		995.64	0.00
						995.64	995.64
2	11/30/2022 SUPER	11/30/2022 Manual	GJ	NOVEMER POSTINGS TO CIP CASH			
				90-000-001.000		116,166.38	0.00
				90-304-001.000	COMMUNITY CENTER	0.00	28,905.00
				90-304-001.000	STREET PROGRAM	0.00	23,359.50
				90-305-001.000	FIRE DEPARTMENT	0.00	63,389.86
				90-320-001.000	TRAILS	0.00	512.02
						116,166.38	116,166.38
3	11/30/2022 SUPER	11/30/2022 Manual	GJ	POSTINGS TO MERF			
				70-000-001.000		2,198.80	0.00
				70-701-001.000	BAHER DONATION	0.00	2,198.80
						2,198.80	2,198.80
4	11/30/2022 SUPER	11/30/2022 Manual	GJ	NONSUFFICIENT FUNDS CHECKS AND CHARGES			
				01-001-700.381	ADMINISTRATION	1,370.04	0.00
				01-004-700.381	COURT	172.00	0.00
				01-000-001.000		0.00	1,542.04
				02-022-700.381	LIBRARY	25.50	0.00
				02-000-001.000		0.00	25.50
						1,567.54	1,567.54
5	11/30/2022 SUPER	11/30/2022 Manual	GJ	NOVEMBER HRA PREMIUMS			
				05-000-700.139		1,962.56	0.00
				05-000-001.000		0.00	1,962.56
						1,962.56	1,962.56
6	11/30/2022 SUPER	11/30/2022 Manual	GJ	MONTHLY SERVICE CHARGES			
				01-001-700.290	SECURITY BANK	206.10	0.00
				01-000-001.000		0.00	206.10
						206.10	206.10
7	11/30/2022 SUPER	11/30/2022 Manual	GJ	LONG FOR THE MONTH			
				09-000-400.500		0.00	13.60
				09-000-001.000		13.60	0.00
						13.60	13.60
8	11/30/2022 SUPER	11/30/2022 Manual	GJ	SHORT FOR THE MONTH			
				09-000-400.500		13.50	0.00
				09-000-001.000		0.00	13.50
						13.50	13.50
9	11/30/2022 SUPER	11/30/2022 Manual	GJ	ELECTRONIC TRANSFER FEES			
				01-001-700.233	RESERVATIONS	137.52	0.00

**JOURNAL ENTRIES**  
MANUAL JOURNALS 11/22

City of Paola

JE #	Entry Date User Name	Posting Date JE Code	Type	Description 1 Description 2 GL #	Description 3 Source Line Distribution Description	Source Desc Debit Amount	Credit Amount
9	11/30/2022 SUPER	11/30/2022 Manual	GJ	ELECTRONIC TRANSFER FEES			
				01-001-700.233	ADMINISTRATION	979.82	0.00
				01-001-700.233	COM CTR/PD/BUILD/CT	239.25	0.00
				01-001-700.233	UB ONLINE	1,423.26	0.00
				01-000-001.000		0.00	2,779.85
						<u>2,779.85</u>	<u>2,779.85</u>
10	11/30/2022 SUPER	11/30/2022 Manual	GJ	SECTION 125 PAYMENTS			
				05-000-700.165		1,204.98	0.00
				05-000-001.000		0.00	1,204.98
						<u>1,204.98</u>	<u>1,204.98</u>
11	11/30/2022 SUPER	11/30/2022 Manual	GJ	CORRECTION			
				90-000-001.000		0.00	4.50
				90-328-001.000	DOG PARK	4.50	0.00
				90-000-001.000		4.50	0.00
				90-317-001.000	GAZEBO RENOVATION	0.00	4.50
						<u>9.00</u>	<u>9.00</u>
12	11/30/2022 SUPER	11/30/2022 Manual	GJ	OPTIONAL GROUP LIFE DIFFERENCE NOVEMBER			
				05-000-700.289		0.03	0.00
				05-000-001.000		0.00	0.03
						<u>0.03</u>	<u>0.03</u>
13	11/30/2022 SUPER	11/30/2022 Manual	GJ	POSTINGS TO MERF			
				70-000-001.000		0.00	9,555.00
				70-701-001.000	BAHER DONATION	7,555.00	0.00
				70-706-001.000	PD BANQUET DONATIONS	2,000.00	0.00
						<u>9,555.00</u>	<u>9,555.00</u>
14	11/30/2022 SUPER	11/30/2022 Manual	GJ	CORRECTION OF SEPTEMBER SALES TAX			
				09-001-700.790	WATER DEPT	1.00	0.00
				09-000-001.000		0.00	1.00
						<u>1.00</u>	<u>1.00</u>
15	11/30/2022 SUPER	11/30/2022 Manual	GJ	SALES AND COMPENSATING USE TAX FOR NOVEMBER			
				01-000-400.042	CITY SALES TAX	0.00	78,175.92
				01-000-400.042	CITY USE TAX	0.00	9,863.45
				01-000-400.043	COUNTY USE TAX	0.00	17,916.70
				01-000-400.043	COUNTY SALES TAX	0.00	55,668.17
				01-000-001.000		161,624.24	0.00
				90-316-400.042	FIRE DEPT CIP	0.00	44,019.69
				90-316-001.000		44,019.69	0.00
				90-315-400.042	PARKS/STREETS SALES TAX	0.00	88,039.38
				90-315-001.000		88,039.38	0.00
						<u>293,683.31</u>	<u>293,683.31</u>
16	11/30/2022 SUPER	11/30/2022 Manual	GJ	KSOP - M. HANSEN(83.04), T. EAKS(185.49) C. TROUTMAN(190.69), L. MARKHAM(178.05)			
				09-000-400.336	WATER SETOFF	0.00	306.54
				09-000-001.000		306.54	0.00

**JOURNAL ENTRIES**  
MANUAL JOURNALS 11/22

City of Paola

JE #	Entry Date User Name	Posting Date JE Code	Type	Description 1 Description 2 GL #	Description 3 Source Line Distribution Description	Source Desc Debit Amount	Credit Amount
16	11/30/2022 SUPER	11/30/2022 Manual	GJ	KSOP - M. HANSEN(83.04), T. EAKS(185.49) C. TROUTMAN(190.69), L. MARKHAM(178.05)			
				04-000-400.336	SEWER SETOFF	0.00	328.96
				04-000-001.000		328.96	0.00
				13-000-400.336	TRASH SETOFF	0.00	1.77
				13-000-001.000		1.77	0.00
						637.27	637.27
17	11/30/2022 SUPER	11/30/2022 Manual	GJ	KANSAS HOUSING RESOURCES PAYMENT ACCOUNT #PEAN-209-3			
				09-000-400.140	WATER	0.00	135.78
				09-000-001.000		135.78	0.00
				04-000-400.200	SEWER	0.00	84.96
				04-000-001.000		84.96	0.00
				13-000-400.300	TRASH	0.00	20.08
				13-000-001.000		20.08	0.00
				12-000-400.400	STORM FUND	0.00	3.30
				12-000-001.000		3.30	0.00
						244.12	244.12
18	11/30/2022 SUPER	11/30/2022 Manual	GJ	KSOP - J. PAULSEN			
				09-000-400.336	WATER SETOFF	0.00	408.24
				09-000-001.000		408.24	0.00
						408.24	408.24
19	11/30/2022 SUPER	11/30/2022 Manual	GJ	OCTOBER SALES TAX PAID			
				09-001-700.790	WATER DEPARTMENT	3,749.49	0.00
				09-000-001.000		0.00	3,749.49
				01-001-700.790	MISC TAX	171.45	0.00
				01-000-001.000		0.00	171.45
						3,920.94	3,920.94
20	11/30/2022 SUPER	11/30/2022 Manual	GJ	TRANSIENT GUEST TAX			
				20-000-400.095		0.00	9,978.92
				20-000-001.000		9,978.92	0.00
						9,978.92	9,978.92
					Grand Total:	445,546.78	445,546.78



RECURRING JOURNAL ENTRIES  
RECURRING JOURNALS 11/22

City of Paola

JE #	Next Posting GL #	Freq	Description	Line Distribution Description	Debit Amount	Credit Amount
2	11/28/2022	MT	Employee Benefits Budget Transfers			
	01-001-700.810			to Fund 5	7,583.34	0.00
	01-002-700.810			to Fund 5	8,389.00	0.00
	01-004-700.810			to Fund 5	931.67	0.00
	01-005-700.810			to Fund 5	9,570.83	0.00
	01-006-700.810			to Fund 5	5,706.25	0.00
	01-007-700.810			to Fund 5	895.83	0.00
	01-009-700.810			to Fund 5	2,812.50	0.00
	01-000-001.000				0.00	35,889.42
	05-000-001.000				35,889.42	0.00
	05-000-400.800			From Fund 1	0.00	35,889.42
	02-022-700.810			to Fund 5	4,583.33	0.00
	02-000-001.000				0.00	4,583.33
	05-000-001.000				4,583.33	0.00
	05-000-400.800			From Fund 2	0.00	4,583.33
	04-001-700.810			to Fund 5	0.00	0.00
	04-032-700.810			to Fund 5	2,083.33	0.00
	04-033-700.810			to Fund 5	6,500.00	0.00
	04-000-001.000				0.00	8,583.33
	05-000-001.000				8,583.33	0.00
	05-000-400.800			From Fund 4	0.00	8,583.33
	07-000-700.810			to Fund 5	2,083.33	0.00
	07-000-001.000				0.00	2,083.33
	05-000-001.000				2,083.33	0.00
	05-000-400.800			From Fund 7	0.00	2,083.33
	08-000-700.810			to Fund 5	1,125.00	0.00
	08-000-001.000				0.00	1,125.00
	05-000-001.000				1,125.00	0.00
	05-000-400.800			from Fund 8	0.00	1,125.00
	09-001-700.810			to Fund 5	0.00	0.00
	09-033-700.810			to Fund 5	0.00	0.00
	09-000-001.000			stopped 7-2022	0.00	0.00
	05-000-001.000				0.00	0.00
	05-000-400.800				0.00	0.00
					104,528.82	104,528.82
3	11/28/2022	MT	Community Center Budget Transfer			
	01-001-700.810			to Fund 8	8,333.33	0.00
	01-000-001.000				0.00	8,333.33
	08-000-400.800			From Fund 1	0.00	8,333.33
	08-000-001.000				8,333.33	0.00
					16,666.66	16,666.66
					121,195.48	121,195.48
				Grand Total:	121,195.48	121,195.48

RECURRING JOURNAL ENTRIES  
 RECURRING JOURNALS 11/22

City of Paola

JE #	Next Posting GL #	Freq	Description	Line Distribution Description	Debit Amount	Credit Amount
16	11/30/2022	MT	1st Monthly Salary Ordinance #22-22			
	01-001-700.100			ADMINISTRATION	15,687.05	0.00
	01-001-700.110			ADMIN CLEANING	634.80	0.00
	01-001-700.120			ADMIN OT	0.00	0.00
	01-001-700.130			COUNCIL	318.47	0.00
	01-002-700.100			POLICE DEPARTMENT	36,476.48	0.00
	01-002-700.110			POLICE PT/CLEANING	155.60	0.00
	01-002-700.120			POLICE OT	4,932.45	0.00
	01-002-700.121			POLICE HOLIDAY OT	0.00	0.00
	01-002-700.272			POLICE ANIMAL CAPTURE	0.00	0.00
	01-003-700.100			FIRE DEPARTMENT	8,431.18	0.00
	01-003-700.110			FIRE DEPARTMENT CLEANING	0.00	0.00
	01-004-700.100			COURT	1,668.80	0.00
	01-004-700.110			JUDGE	1,399.74	0.00
	01-005-700.100			STREETS DEPARTMENT	13,408.80	0.00
	01-005-700.120			STREETS DEPT OT	482.02	0.00
	01-006-700.100			PARKS DEPARTMENT	7,348.80	0.00
	01-006-700.110			PARKS DEPT PT	858.50	0.00
	01-006-700.120			PARKS DEPT OT	0.00	0.00
	01-007-700.100			CEMETERY	0.00	0.00
	01-007-700.120			CEMETERY OT	0.00	0.00
	01-009-700.100			COMMUNITY DEVO	5,794.40	0.00
	01-009-700.110			COMMUNITY DEVO PT	0.00	0.00
	01-000-001.000				0.00	97,597.09
	02-022-700.100			LIBRARY	4,507.13	0.00
	02-022-700.110			LIBRARY PT	1,592.63	0.00
	02-022-700.111			LIBRARY AIDES	905.31	0.00
	02-022-700.120			LIBRARY OT	0.00	0.00
	02-000-001.000				0.00	7,005.07
	04-001-700.100			SEWER DEPARTMENT	0.00	0.00
	04-001-700.120			SEWER DEPT OT	0.00	0.00
	04-001-700.130			COUNCIL	0.00	0.00
	04-032-700.100			SEWER PRODUCTION OT	2,277.14	0.00
	04-032-700.120			SEWER PRODUCTION OT	124.97	0.00
	04-033-700.100			SEWER DISTRIBUTION	5,013.60	0.00
	04-033-700.120			SEWER PRODUCTION OT	2,278.63	0.00
	04-000-001.000				0.00	9,694.34
	07-000-700.100			POOL	0.00	0.00
	07-000-700.110			POOL PT	0.00	0.00
	07-000-700.120			POOL OT	0.00	0.00
	07-000-700.130			COUNCIL	0.00	0.00
	07-000-001.000				0.00	0.00
	08-000-700.100			COMMUNITY CENTER	2,459.60	0.00
	08-000-700.110			COMMUNITY CTR CLEANING	297.39	0.00
	08-000-700.120			COMMUNITY CTR OT	0.00	0.00
	08-000-001.000				0.00	2,756.99
	09-001-700.100			WATER DEPARTMENT	0.00	0.00
	09-001-700.130			COUNCIL	0.00	0.00
	09-032-700.100			WATER PRODUCTION	0.00	0.00
	09-032-700.120			WATER PRODUCTION OT	0.00	0.00
	09-033-700.100			WATER DISTRIBUTION	1,407.20	0.00
	09-033-700.120			WATER DISTRIBUTION OT	290.23	0.00
	09-000-001.000				0.00	1,697.43
	12-033-700.100			STORM WTR MGMT	0.00	0.00

RECURRING JOURNAL ENTRIES  
RECURRING JOURNALS 11/22

City of Paola

JE #	Next Posting GL #	Freq	Description	Line Distribution Description	Debit Amount	Credit Amount
16	11/30/2022	MT	1st Monthly Salary Ordinance #22-22			
	12-033-700.120			STORM WTR MGMT OT	0.00	0.00
	12-000-001.000				0.00	0.00
	13-032-700.100			HEALTH & SANITATION	0.00	0.00
	13-000-001.000				0.00	0.00
	16-000-700.100			WW TREAT PLANT	0.00	0.00
	16-000-700.120			WW TREAT PLANT OT	0.00	0.00
	16-000-001.000				0.00	0.00
	17-005-700.100			SPECIAL STREETS	0.00	0.00
	17-000-001.000				0.00	0.00
	05-000-700.125			FINAL BENEFITS - HYLTON	0.00	0.00
	05-000-700.125				0.00	0.00
	05-000-700.125				0.00	0.00
	05-000-001.000				0.00	0.00
					118,750.92	118,750.92
17	11/30/2022	MT	FICA & MEDICARE NOVEMBER			
	05-000-700.150			SAL ORD #22-22 PAY 11/2/22	8,725.71	0.00
	05-000-001.000				0.00	8,725.71
	05-000-700.150			SAL ORD #22-23 PAY 11/16/22	8,711.49	0.00
	05-000-001.000				0.00	8,711.49
	05-000-700.150			SAL ORD #22-24 PAY 11/30/22	9,085.29	0.00
	05-000-001.000				0.00	9,085.29
	05-000-700.150				0.00	0.00
	05-000-001.000				0.00	0.00
	05-000-700.150				0.00	0.00
	05-000-001.000				0.00	0.00
					26,522.49	26,522.49
18	11/30/2022	MT	KPERS & KP&F for the month of NOVEMBER			
	05-000-700.160			KPERS CITY	6,616.82	0.00
	05-000-700.160			KPF PD	7,661.09	0.00
	05-000-700.160			KPF PD ADJUSTMENT	0.00	0.00
	05-000-700.160			KPERS Library	581.00	0.00
	05-000-700.160			KPERS After Retire Library	0.00	0.00
	05-000-001.000			SAL ORD #22-22 PAY 11/2/22	0.00	14,858.91
	05-000-700.160			KPERS City	6,355.53	0.00
	05-000-700.160			KPERS After Retire City	0.00	0.00
	05-000-700.160			KPF	7,560.51	0.00
	05-000-700.160			KPERS Library	573.24	0.00
	05-000-700.160			KPERS After Retire Library	0.00	0.00
	05-000-001.000			SAL ORD #22-23 PAY 11/16/22	0.00	14,489.28
	05-000-700.160			KPERS City	6,351.22	0.00
	05-000-700.160			KPERS After Retire City	0.00	0.00
	05-000-700.160			KPF	8,218.99	0.00
	05-000-700.160			KPERS Library	588.77	0.00
	05-000-700.160			KPERS After Retire Library	0.00	0.00
	05-000-001.000			SAL ORD #22-24 PAY 11/30/22	0.00	15,158.98
	05-000-700.160			KPERS City	0.00	0.00
	05-000-700.160			KPF	0.00	0.00
	05-000-700.160			KPERS Library	0.00	0.00
	05-000-001.000				0.00	0.00
					44,507.17	44,507.17
19	11/30/2022	MT	2nd Monthly Salary Ordinance #22-23			
	01-001-700.100			ADMINISTRATION	15,524.60	0.00

RECURREN JOURNAL ENTRIES  
 RECURREN JOURNALS 11/22

City of Paola

JE #	Next Posting GL #	Freq	Description	Line Distribution Description	Debit Amount	Credit Amount
19	11/30/2022	MT	2nd Monthly Salary Ordinance #22-23			
	01-001-700.110			ADMIN CLEANING	571.32	0.00
	01-001-700.120			ADMIN OT	0.00	0.00
	01-001-700.130			COUNCIL	318.47	0.00
	01-002-700.100			POLICE DEPARTMENT	35,393.12	0.00
	01-002-700.110			POLICE PT/CLEANING	216.48	0.00
	01-002-700.120			POLICE DEPT OT	5,161.61	0.00
	01-002-700.121			POLICE DEPT HOLIDAY OT	0.00	0.00
	01-002-700.272			POLICE ANIMAL CARE	200.00	0.00
	01-003-700.100			FIRE DEPARTMENT	11,546.18	0.00
	01-003-700.110			FIRE DEPT CLEANING	0.00	0.00
	01-004-700.100			COURT	1,668.80	0.00
	01-004-700.110			JUDGE	1,399.74	0.00
	01-004-700.120			COURT OT	0.00	0.00
	01-005-700.100			STREETS	13,932.80	0.00
	01-005-700.120			STREETS OT	0.00	0.00
	01-006-700.100			PARKS	7,375.30	0.00
	01-006-700.110			PARKS PT	389.50	0.00
	01-006-700.120			PARKS OT	0.00	0.00
	01-007-700.100			CEMETERY DEPT	0.00	0.00
	01-007-700.120			CEMETERY DEPT OT	0.00	0.00
	01-009-700.100			COMMUNITY DEVO	5,794.40	0.00
	01-009-700.110			COMMUNITY DEVO PT	0.00	0.00
	01-000-001.000				0.00	99,492.32
	02-022-700.100			LIBRARY	4,539.86	0.00
	02-022-700.110			LIBRARY PT	1,437.86	0.00
	02-022-700.111			LIBRARY AIDES	896.43	0.00
	02-022-700.120			LIBRARY OT	8.65	0.00
	02-000-001.000				0.00	6,882.80
	04-001-700.100			SEWER DEPARTMENT	0.00	0.00
	04-001-700.120			SEWER OT	0.00	0.00
	04-001-700.130			COUNCIL	0.00	0.00
	04-032-700.100			SEWER PRODUCTION	2,221.60	0.00
	04-032-700.120			SEWER PRODUCTION OT	83.31	0.00
	04-033-700.100			SEWER DISTRIBUTION	4,981.92	0.00
	04-033-700.120			SEWER DISTRIBUTION OT	393.31	0.00
	04-000-001.000				0.00	7,680.14
	07-000-700.100			POOL	0.00	0.00
	07-000-700.110			POOL PT	0.00	0.00
	07-000-700.120			POOL OT	0.00	0.00
	07-000-700.130			COUNCIL	0.00	0.00
	07-000-001.000				0.00	0.00
	08-000-700.100			COMMUNITY CTR	2,459.60	0.00
	08-000-700.110			COMM CTR CLEANING	238.00	0.00
	08-008-700.110			COMM CTR SEP	0.00	0.00
	08-000-001.000				0.00	2,697.60
	09-001-700.100			WATER DEPARTMENT	0.00	0.00
	09-001-700.130			COUNCIL	0.00	0.00
	09-032-700.100			WATER PRODUCTION	0.00	0.00
	09-032-700.120			WATER PROD OT	0.00	0.00
	09-033-700.100			WATER DISTRIBUTION	1,407.20	0.00
	09-033-700.120			WATER DIST OT	39.58	0.00
	09-000-001.000				0.00	1,446.78
	12-033-700.100			STORM WATER MGMT	0.00	0.00

RECURRING JOURNAL ENTRIES  
RECURRING JOURNALS 11/22

City of Paola

JE #	Next Posting GL #	Freq	Description	Line Distribution Description	Debit Amount	Credit Amount
19	11/30/2022	MT	2nd Monthly Salary Ordinance #22-23			
	12-033-700.120			STORM WATER MGMT OT	0.00	0.00
	12-000-001.000				0.00	0.00
	13-032-700.100			HEALTH & SANITATION	0.00	0.00
	13-032-700.120			HEALTH & SANITATION OT	0.00	0.00
	13-000-001.000				0.00	0.00
	16-000-700.100			WW TREAT PLANT	0.00	0.00
	16-000-700.120			WW TREAT PLANT OT	0.00	0.00
	16-000-001.000				0.00	0.00
	17-005-700.100			SPECIAL STREETS	0.00	0.00
	17-005-700.120			SPECIAL STREETS OT	0.00	0.00
	17-000-001.000				0.00	0.00
	05-000-700.125				0.00	0.00
	05-000-700.125				0.00	0.00
	05-000-001.000				0.00	0.00
					118,199.64	118,199.64
20	11/30/2022	MT	3rd Monthly Salary Ordinance #22-24			
	01-001-700.100			ADMINISTRATION	15,449.60	0.00
	01-001-700.110			ADMIN PT/CLEANING	603.06	0.00
	01-001-700.120			ADMIN OT	0.00	0.00
	01-001-700.130			COUNCIL	318.47	0.00
	01-002-700.100			POLICE DEPARTMENT	35,407.55	0.00
	01-002-700.110			POLICE DEPT PT/CLEANING	236.77	0.00
	01-002-700.120			POLICE DEPT OT	4,751.41	0.00
	01-002-700.121			POLICE DEPT HOLIDAY OT	3,739.19	0.00
	01-002-700.272			POLICE ANIMAL CARE	100.00	0.00
	01-003-700.100			FIRE DEPARTMENT	8,968.68	0.00
	01-004-700.100			COURT	1,668.80	0.00
	01-004-700.110			JUDGE	1,399.74	0.00
	01-005-700.100			STREET DEPARTMENT	13,408.80	0.00
	01-005-700.110			STREET DEPT PT	0.00	0.00
	01-005-700.120			STREET DEPT OT	0.00	0.00
	01-006-700.100			PARKS DEPARTMENT	7,683.52	0.00
	01-006-700.110			PARKS DEPT PT	389.50	0.00
	01-006-700.120			PARKS DEPT OT	0.00	0.00
	01-007-700.100			CEMETERY DEPARTMENT	0.00	0.00
	01-007-700.120			CEMETERY DEPT OT	0.00	0.00
	01-009-700.100			COMMUNITY DEVO	5,794.40	0.00
	01-009-700.110			COMMUNITY DEVO PT	0.00	0.00
	01-009-700.120			COMMUNITY DEVO OT	0.00	0.00
	01-000-001.000				0.00	99,919.49
	02-022-700.100			LIBRARY	4,515.78	0.00
	02-022-700.110			LIBRARY PT	1,620.50	0.00
	02-022-700.111			LIBRARY AIDES	1,219.29	0.00
	02-022-700.120			LIBRARY OT	0.00	0.00
	02-000-001.000				0.00	7,355.57
	04-001-700.100			SEWER DEPARTMENT	0.00	0.00
	04-001-700.130			COUNCIL	0.00	0.00
	04-032-700.100			SEWER PRODUCTION	2,450.70	0.00
	04-032-700.120			SEWER PRODUCTION OT	0.00	0.00
	04-033-700.100			SEWER DISTRIBUTION	5,021.52	0.00
	04-033-700.120			SEWER DISTRIBUTION OF	0.00	0.00
	04-000-001.000				0.00	7,472.22
	07-000-700.110			POOL PT	0.00	0.00

RECURRING JOURNAL ENTRIES

RECURRING JOURNALS 11/22

Page: 5

12/8/2022

3:53 pm

City of Paola

JE #	Next Posting GL #	Freq	Description	Line Distribution Description	Debit Amount	Credit Amount
20	11/30/2022	MT	3rd Monthly Salary Ordinance #22-24			
	07-000-700.120			POOL OT	0.00	0.00
	07-000-001.000				0.00	0.00
	08-000-700.100			COMMUNITY CENTER	2,409.60	0.00
	08-000-700.110			COMMUNITY CTR CLEANING	189.00	0.00
	08-000-001.000				0.00	2,598.60
	09-001-700.100			WATER DEPARTMENT	0.00	0.00
	09-001-700.130			COUNCIL	0.00	0.00
	09-032-700.100			WATER PRODUCTION	0.00	0.00
	09-032-700.120			WATER PRODUCTION OT	0.00	0.00
	09-033-700.100			WATER DISTRIBUTION	1,415.99	0.00
	09-033-700.120			WATER DISTRIBUTION OT	0.00	0.00
	09-000-001.000				0.00	1,415.99
	12-033-700.100			STORM WTR MGMT	0.00	0.00
	12-033-700.120			STORM WTR MGMT OT	0.00	0.00
	12-000-001.000				0.00	0.00
	13-032-700.100			HEALT & SANITATION	0.00	0.00
	13-000-001.000				0.00	0.00
	16-000-700.100			WW TREAT PLANT	0.00	0.00
	16-000-700.120			WW TREAT PLANT OT	0.00	0.00
	16-000-001.000				0.00	0.00
	17-005-700.100			SPECIAL STREETS	0.00	0.00
	17-000-001.000				0.00	0.00
	05-000-700.125				0.00	0.00
	05-000-001.000				0.00	0.00
					118,761.87	118,761.87
				Grand Total:	426,742.09	426,742.09

**JOURNAL ENTRIES**  
**MANUAL JOURNALS 11/22**

City of Paola

JE #	Entry Date User Name	Posting Date JE Code	Type	Description 1 Description 2 GL #	Description 3 Source Line Distribution Description	Source Desc Debit Amount	Credit Amount
1	11/30/2022 SUPER	11/30/2022 Manual	GJ	REVERSAL OF CIP CASH			
				90-000-001.000		0.00	116,166.38
				90-304-001.000	COMMUNITY CENTER	52,264.50	0.00
				90-305-001.000	STREET PROGRAM	63,389.86	0.00
				90-320-001.000	TRAILS	512.02	0.00
						<u>116,166.38</u>	<u>116,166.38</u>
2	11/30/2022 SUPER	11/30/2022 Manual	GJ	NOVEMBER POSTINGS TO CIP CASH			
				90-000-001.000		116,166.38	0.00
				90-304-001.000	COMMUNITY CENTER	0.00	28,905.00
				90-305-001.000	STREET PROGRAM	0.00	23,359.50
				90-316-001.000	FIRE DEPARTMENT	0.00	63,389.86
				90-320-001.000	TRAILS	0.00	512.02
						<u>116,166.38</u>	<u>116,166.38</u>
					Grand Total:	<u>232,332.76</u>	<u>232,332.76</u>



---

**SUBJECT:     Liquor License Renewal**  
**CONTACT:    Stephanie Marler, City Clerk**  
**DATE:         December 13, 2022**

---

**Background**

Carl Clinton, owner of Papa C's, will have a liquor license renewal due January 13, 2023. Due to the timing of the January meeting, approval for the renewal is being considered in December.

**Summary**

The Council needs to take action to renew the liquor license for Papa C's. Mr. Clinton will need to return the proper application, fee and pass the fire safety inspection.

**Financial Impact (or Fiscal Note)**

Carl Clinton pays the annual fee of \$250 to maintain his license and the city will also benefit from the sales and liquor tax revenue.

**Recommendations**

I recommend the Drinking Establishment license for Papa C's be approved with the consent agenda contingent upon approved safety inspection.





---

**SUBJECT: 2023 CMB License Renewals**  
**CONTACT: Stephanie Marler, City Clerk**  
**DATE: December 13, 2022**

---

**Background**

Businesses that hold a CMB License must renew that license annually in December for the following year. The owner must submit the City and State application, fee for on premises and/or off premises consumption and pass the fire safety inspection.

**Issue**

The following is a listing of each applicant.

<u>NAME</u>	<u>ADDRESS</u>	<u>LICENSE</u>	<u>FEE</u>
CASEY'S GENERAL STORE #1237	119 N. HOSPITAL DR	CMB – OFF PREMISES	\$75.00
CASEY'S GENERAL STORE #1337	404 S. SILVER	CMB – OFF PREMISES	\$75.00
FUEL EXPRESSO #15	1005 N. PEARL	CMB – OFF PREMISES	\$75.00
WALMART	310 HEDGE LANE	CMB – OFF PREMISES	\$75.00
PRICE CHOPPER	309 N. HOSPITAL DR	CMB – OFF PREMISES	\$75.00
MILO'S STEAK HOUSE	16 W. PEORIA	CMB – ON PREMISES	\$125.00
PIZZA HUT	1613 E PEORIA	CMB – ON PREMISES	\$125.00
<b>* ONE STOP CONVENIENCE</b>	<b>604 N SILVER</b>	<b>CMB – OFF PREMISES</b>	<b>\$75.00</b>

\* One Stop Convenience was approved for a new CMB license at the November 8, 2022 meeting. The building is still under construction but they intend to be open prior to the December 31, 2022 expiration date.

**Financial Impact (or Fiscal Note)**

Each fee includes a \$25 stamp fee that will be sent to the State of Kansas, the remaining revenue will go into the general fund. The city will also benefit from the sales tax collected.

**Recommendations**

I recommend the Council approve these license renewals contingent upon passed safety inspections and receipt of all required documents and fees as part of the Consent Agenda.



---

**SUBJECT: General Election Results 2022**  
**CONTACT: Stephanie Marler, City Clerk**  
**DATE: December 13, 2022**

---

**Background**

A general election was held November 8, 2022 to elect Council Members from Ward 2 and Ward 4. The votes were canvassed by the Miami County Board of Canvassers on November 17, 2022. The City Council needs to take action to accept the Certificate of Election Results.

**Issue**

The official results of the Election are as follows:

**Paola City Council – Ward 2**

Trent Upshaw	326
Write-Ins	8
Total	334

**Paola City Council – Ward 4**

LeAnne Shields	522
Write-Ins	18
Total	540

**Summary**

Official Election Results show Trent Upshaw with the most votes in Ward 2 and LeAnne Shields with the most votes in Ward 4. Trent Upshaw moved and is no longer eligible for the Ward 2 City Council seat. Deborah Hayes was elected by the City Council in October 2022 to fill the remainder of Trent's term. Deborah is interested in continuing to serve on the council and no other letters of interest have been submitted to the City Clerk's office.

**Recommendations**

I recommend the Certificate of Election Results be accepted showing Trent Upshaw and LeAnne Shields with the most votes.

**Attachments**

Certificate of Election Results

Janet White  
Miami County Clerk  
201 S. Pearl, Suite 102  
Paola, Kansas 66071



Phone: (913) 294-3976  
Fax: (913) 294-9544  
countyclerk@miamicountyks.org  
www.miamicountyks.org

City of Paola  
19 E Peoria St  
Paola, KS 66071

I, Janet White, Miami County Election Officer, do hereby certify the votes for the November 8, 2022, General Election as canvassed by the Miami County Board of Canvassers on November 17, 2022, in the Public Information/Election Verification Room, and hereby declare the following election results.

Done this 17th day of November 2022

**Paola City Council**

**Precinct 2**

Trent Upshaw	326*
Write-in Votes	8

**Precinct 4**

LeAnne Shields	522*
Write-in Votes	18

DONE THIS 5<sup>th</sup> DAY OF DECEMBER, 2022.



Janet White  
Miami County Clerk



---

**SUBJECT: Council Election to fill Ward 2 seat**  
**CONTACT: Stephanie Marler, City Clerk**  
**DATE: December 13, 2022**

---

**Background**

Ward 2 Council Seat was up for election on November 8, 2022. The official ballot showed former Council Member Trent Upshaw running unopposed. Mr. Upshaw moved from Ward 2 in September of 2022 and Deborah Hayes was elected by the City Council to fill the remainder of the term.

**Issue**

The official election results show Trent Upshaw as the candidate with the most votes in Ward 2, although he is no longer qualified. The City Council will be tasked with electing a member from Ward 2 to fill the 2 year term.

Qualified electors in Ward 2 were notified by newspaper, city website, and facebook of the open seat. Interested residents in that ward were asked to submit a letter of interest to the City Clerk's office by 4:00 pm on December 8th if they would like to fill the seat for the remainder of the term. A Council Election will be held at the meeting to fill the vacancy.

**1-207. Vacancies on the governing body; how filled.**

(a) All vacancies occurring in the office of City Councilmembers for the City of Paola, Kansas, whether such vacancies occur by reason of the removal of a Councilmember from his/her Ward or by his/her death, resignation, the failure of a Councilmember to qualify for office, or the disqualification of a Councilmember for the holding of such office shall be filled by an election held among the remaining members of the City Council of said City, and such election must be held at the next regular meeting of the Governing Body of said City or at a special meeting called therefor for the purpose of filling such vacancy or at an adjournment or continuance of such regular or special meeting and any successor in office elected by the Governing Body to fill such vacancy must be elected by a majority of the remaining Councilmembers of said City, and should the remaining Councilmembers of said City fail to elect a successor in office for the vacancy in office of Councilmembers after being polled three (3) times by the

---

Mayor, or in his/her absence, the President of the Council of said City, then and in that event, the Mayor, or in his/her absence, the President of the Council, of said City, shall appoint a qualified person from the Ward in which said vacancy exists to fill such unexpired term, and in the event that any person so elected by the remaining members of the Council or appointed by the Mayor or President of the Council in the manner aforesaid, should refuse, fail or neglect to qualify for such office by taking or subscribing to his/her oath for a period of ten (10) days following such election or appointment, as the case may be, then and in the event, the Mayor of said City shall forthwith appoint another qualified person to fill such vacancy.

(b) In case of a vacancy in the office of mayor, the president of the council shall become mayor until the next regular election for that office and a vacancy shall occur in the office of the council member becoming mayor.

(K.S.A. 14-204; K.S.A. 14-308; Prior Code 2016 §105.050; C.O. No. 6; C.O. No. 20; Code 2021)

**Summary**

The Council is free to nominate any qualified candidate that they desire. As of the requested submission date, 2 individuals have expressed interest in serving on the city council. Any Councilmember can make a motion to nominate an individual, if the motion receives a “second” and the majority approves, the nominee is elected.

**Legal Impact (or Review)**

The League of Kansas Municipalities suggested following the process again once the November election is over since Mr. Upshaw received the most votes for Ward 2.

**Recommendations**

Motion to nominate \_\_\_\_\_ to fill the position of Ward 2 City Council Member.

**Attachment**

Deborah Hayes Letter of Interest

Jennifer (Jenna) Dees Letter of Interest

November 18, 2022

Paola City Hall  
Attention: City Clerk  
P.O. Box 409  
Paola, Kansas 66071  
[smarler@paolagov.org](mailto:smarler@paolagov.org)

Dear Mayor Leigh Grandon House and members of the Council.

I understand that Trent Upshaw won the election for City Council Ward 2. I would like to be considered for that position. I have thoroughly enjoyed the short time I've served alongside the other Council members and would like to continue serving, and learning more about the direction of Paola.

I am writing to inform you that I am a qualified elector in Ward 2, Paola, Kansas, and I am interested in filling the vacancy in my Ward.

My name is Deborah Diann Hayes, and have lived at 408 S. Silver Street for 24 years. I'm a proud member of my community and would be honored to play a role in the governing body that sees to the welfare of this beautiful town.

A little bit about me...

I was a stay at home mom until our youngest started kindergarten; at which time, I began my 24-year career as a paraprofessional for USD 368. I currently work at Paola Middle School as a Resource Paraprofessional. I have found such joy learning to meet the needs of my students while watching them find their potential. Below is a little bit about how I've served our schools and community:

- I was the PTO President at Sunflower Elementary for 3 years.
- I served on the Bond Issue Committee for Cottonwood Elementary.
- I served on the Steering Committee for Cottonwood Elementary.
- I served on the Site Council for Cottonwood and Sunflower Elementary.
- I served on my church board at Grace Community for 4 years.

I've been married to my adoring husband for 35 years. I grew up in this town, and the memories and small town life flood my mind and fill my heart. We have three grown children that are all married, and we have the best 4 grandchildren in the world. Our kids all went through Paola schools and have very fond memories of growing up in this small town.

I feel like I would be a good candidate for this position because I care deeply for this town and want to see it continue to grow in healthy directions while still maintaining the small town feel. I see empty buildings that deserve a business in them and I hear the concerns of citizens including the ways they would like to see Paola thrive. I would like to do my part to care for this community alongside the mayor and council members in order to keep and make life in Paola one that families want to be a part of.

Thank you for your consideration. I look forward to hearing from you.

Respectfully,

  
Deborah D Hayes



Jennifer (Jenna) Dees  
208 E Peoria St  
Paola, KS 66071

December 8, 2022

Stephanie Marler  
City Clerk  
Paola City Hall  
PO Box 409  
Paola, KS 66071

Greetings,

I would like to submit my information in consideration for the City of Paola Ward 2 vacancy. I am attaching my resume for reference.

I moved to Paola when I was in 8<sup>th</sup> grade and lived in Paola until I moved away to attend Emporia State. I moved back in 2012, my children attended and graduated from Paola schools. I currently work from home as a specialty property underwriter as well as owning Destinations Travel, a local home-based travel agency. I'm grateful that both roles allow me flexibility in my workday.

I would like the opportunity to serve on the city council as I love our little town and want to help it continue to be a great town. However, most importantly, I want to ensuring constituents in Ward 2 are able to have someone work with them and on their behalf.

I value teamwork. I also value listening to others, even when opinions are not the same. Being able to see another person's point of view is impossible without listening and teamwork. I believe in being respectful to each other, remembering that just because you can, doesn't mean you should and thinking through decisions with an eye on not only the immediate outcomes but the long term as well.

Many years ago, my sister came to visit from San Antonio. She was surprised that we had a taxi service. I told her at the time, "Not only do we have a taxi service, but it's our mayor." She laughed and said, "Could you get any more Stars Hollow than that?" (Referencing the fictional location on the TV Series, Gilmore Girls). Even though our local taxi driver has retired from being our mayor, it makes me smile when I think of how "Stars Hollow" our town is. We have the small-town feel, where you know your neighbor, we have some beautiful public areas, fabulous small businesses, wonderful events, and people who care about the community and the people in it.

I know I will not be the only person submitting my name for this position. I'm confident that whomever the city council chooses to fill the role, it will be the best person for the job. If that person is me, I'm excited to get to help our community.

Sincerely,

*Jenna Dees*

Jennifer (Jenna) Dees



**Paola City Council  
Memorandum**

**Agenda Item 7**

---

**SUBJECT: Annual Election of Council Officers**  
**CONTACT: Stephanie Marler, City Clerk**  
**DATE: December 13, 2022**

---

**Introduction**

With the installment of the new City Council, a President and Vice President must be elected to serve in the absence of the Mayor.

**Background**

City Code:

**1-206. President of the council.**

The city council shall elect one of its own body as president of the council. The president of the council shall preside at all meetings of the council in the absence of the mayor. In the absence of both the mayor and the president of the council, the council shall elect one of its members as “acting president of the council.” The president and acting president, when occupying the place of mayor, shall have the same privileges as other councilmembers.

(K.S.A. 14-204; Prior Code 2016 §105.110; Code 2021)

**Issue**

Council needs to take action to nominate and elect officers.

**Alternatives**

None

**Recommendations**

I recommend that Council elect a President and Vice President pursuant to Section 1-206 of the Municipal Code of the City of Paola.



---

**SUBJECT: Annual Election of Council Officers**  
**CONTACT: Stephanie Marler, City Clerk**  
**DATE: December 13, 2022**

---

**Introduction**

With the installment of the new City Council, a President and Vice President must be elected to serve in the absence of the Mayor.

**Background**

City Code:

**1-206. President of the council.**

The city council shall elect one of its own body as president of the council. The president of the council shall preside at all meetings of the council in the absence of the mayor. In the absence of both the mayor and the president of the council, the council shall elect one of its members as “acting president of the council.” The president and acting president, when occupying the place of mayor, shall have the same privileges as other councilmembers.

(K.S.A. 14-204; Prior Code 2016 §105.110; Code 2021)

**Issue**

Council needs to take action to nominate and elect officers.

**Recommendations**

I recommend that Council elect a President and Vice President pursuant to Section 1-206 of the Municipal Code of the City of Paola.



---

**SUBJECT: Landworks Studio Contract**  
**CONTACT: Randi Shannon, City Manager**  
**DATE: December 13, 2022**

---

**Introduction**

The Paola Family Pool was constructed in 1996 and is in need of rehabilitation and updates/upgrades to serve today's sophisticated users. In the fall of 2019, Paola citizens approved a one-half cent retailer sales tax, with a portion of the revenues dedicated specifically to improve, maintain and operate the Paola Family Pool.

**Background**

The City of Paola approved the proposal from Landworks Studios, in response to the Paola Family Pool Improvements Request for Qualification at the October 11, 2022 Council meeting. After the selection, City staff met with Landwork Studios to establish the scope and enhancements for the firm to establish the total fee for the engineering services, design work, and construction administration.

**Summary**

Attached is the contract from Landworks Studio for the total of \$201,950. The contract includes the following itemized fees:

**Phase 1: Kick off and Prioritization Meeting**

**Phase 2: Schematic Design**

**Phase 3: Design Development**

**Phase 4: Construction Administration**

**Phase 5: Bidding**

**Phase 6: Construction Administration**

**Phase 7: Reimbursable Expenses**

**Phase 8: Geotechnical Investigation**

Landworks Studio has also acquired the below sub-consultants for this project:

**Allenbrand-Drews & Associates, Inc.**

**Braun-Intertec**

**SFS Architects**

**Water Technology, Inc.**

**Discussion**

From discussion with Landworks Studios and their sub-consultant, Water Technology, Inc. the plan is to update the safety concerns in the mechanical room before the start of the 2023 pool season. Then after the close of the 2023 season, construction will begin on the enhancements for the 2024 season. Below are the items that are to be done prior to the opening of the 2023 season.

1. Removing the sand from the existing sand filters and replacing the media
2. Remove the existing pool heater and install a new high efficiency pool heater
3. Renovate the pool chemical storage rooms to properly isolate the storage of liquid chlorine from the muriatic acid.

**Legal Impact (or Review)**

The City Attorney is reviewing the contract and will state if there are any concerns at the City Council meeting.

**Financial Impact (or Fiscal Note)**

The one-half cent retailer sales tax, with a portion of the revenues dedicated specifically to improve, maintain and operate the Paola Family Pool will be utilized for payment.

**Recommendations**

I recommend approval of the contract from Landworks Studio in the form substantially presented and authorize the necessary signatures.

**Attachments**

1. Draft Contract



102 S. Cherry Street, 2nd Floor • Olathe, KS 66061 • 913.780.6707

To	Project
Randi Shannon City of Paola, KS 19 E Peoria Paola, KS 66071	Paola Family Pool Improvements - Paola, KS

Thank you for the opportunity to present this contract to you for the upgrades and renovations for Family Pool.

Scope of Services

Our services include site survey on the north side of the existing pool decking, and geotechnical reporting for 3 borings for the proposed slide and shade structure. Site plans will be provided to determine the best locations for these improvements. The scope also includes mechanical and aquatic design services to improve safety and efficiency in the mechanical room. Additionally, new amenities will be selected and designed to add play value to the zero depth entry area of the existing pool. Architectural services to provide a fresh, updated and easier to maintain entry building is also included in our scope of services.

Reimbursables are included as a line item in our scope and fee and include travel, lodging and meal expenses for out of town team members.

For a more detailed list of services and fees, refer to the Scope and Fee Outline provided. Any additional services are also included in the same format.

Itemized Fees

Phase 1 - Kick Off and Prioritization Meeting	Fixed Fee	16,720.00
Phase 2 - Schematic Design	Fixed Fee	35,290.00
Phase 3 - Design Development	Fixed Fee	55,330.00
Phase 4 - Construction Documentation	Fixed Fee	64,280.00
Phase 5 - Bidding	Fixed Fee	2,560.00
Phase 6 - Construction Administration	Fixed Fee	17,350.00
Phase 7 - Reimbursable Expenses	Fixed Fee	4,500.00
Phase 8 - Geotechnical Investigation	Fixed Fee	5,920.00
		\$ 201,950.00

Sub-Consultants

Allenbrand-Drews & Associates, Inc.  
Braun-Intertec  
SFS Architecture  
Water Technology, Inc.

---

## SECTION 1 - BASIC SERVICES OF LANDSCAPE ARCHITECT

### 1.1 General.

1.1.1. The Basic Services to be performed by LANDWORKS STUDIO, hereinafter referred to as LANDSCAPE ARCHITECT, are defined in the attached proposal letter agreement, hereinafter referred to as Letter of Agreement. When Letter of Agreement is signed by both parties, with the second party hereinafter referred to as CLIENT, the Letter of Agreement invokes the Standard Agreement and Terms and Conditions contained herein.

1.1.2. The part of the Project for which LANDSCAPE ARCHITECT is to provide services described in the attached Letter of Agreement and in this document is hereinafter referred to as This Part of the Project.

1.1.3. LANDSCAPE ARCHITECT will collaborate with CLIENT and CLIENT's consultants to the extent required to provide a coordinated design for the overall Project. Except as set forth herein, LANDSCAPE ARCHITECT will not have any duties or responsibilities for any other part of the Project. LANDSCAPE ARCHITECT will perform services in character sequence and timing so that it will be coordinated with that of CLIENT and other consultants for the Project.

1.1.4. If you have chosen not to have the LANDSCAPE ARCHITECT and the consultants of the LANDSCAPE ARCHITECT provide construction administration services on the project, then those services shall be excluded from our contract. The CLIENT shall then assume the liability to ensure that the project is constructed in accordance with the design of the LANDSCAPE ARCHITECT and the CLIENT will hold the LANDSCAPE ARCHITECT harmless from any claim due to the contractor not building per plans and specifications.

## SECTION 2 - ADDITIONAL SERVICES

### 2.1 General.

If authorized in writing by the CLIENT, LANDSCAPE ARCHITECT shall furnish or obtain from others, Additional Services which are not considered normal or customary Basic Services except to the extent provided in the attached Letter of Agreement. Additional Services will be paid for by CLIENT as indicated in Section 5.

## SECTION 3 - CLIENT'S RESPONSIBILITIES

CLIENT shall:

3.1. Provide all criteria and full information as to CLIENT's requirements for the Project including: design objectives and constraints, space, capacity and performance requirements, flexibility and expandability, and any budgetary limitations. Furnish copies of all design and construction standards which CLIENT will require to be included in the Drawings and Specifications.

3.2. Assist LANDSCAPE ARCHITECT by placing at his disposal all available information pertinent to the Project including previous reports and any other data relative to design or construction of the Project.

3.3. Arrange for access to and make all provisions for LANDSCAPE ARCHITECT to enter upon public and private property as required for LANDSCAPE ARCHITECT to perform his services.

3.4. Furnish, or direct LANDSCAPE ARCHITECT in writing to provide, necessary Additional Services as stipulated in Section 2 of this Agreement or other services as required.

3.5. Bear all costs incident to compliance with the requirements of this Section 3.

## SECTION 4 - PERIOD OF SERVICE

4.1. The provisions of this Section 4 and the various rates of compensation for LANDSCAPE ARCHITECT's services provided for elsewhere in this Agreement have been agreed to in anticipation of the orderly and continuous progress of the Project through completion of the Design Phase (unless otherwise stated in attached proposal letter). LANDSCAPE ARCHITECT's obligation to render services hereunder will extend for a period that may reasonably be required for the design (unless otherwise stated in attached proposal letter) of This Part of the Project; including extra work and required extensions thereto.

4.2. If LANDSCAPE ARCHITECT's services for design (or phases as stated in attached proposal letter) of This Part of the Project are delayed or suspended (In whole or in part) by CLIENT for more than two weeks for reasons beyond LANDSCAPE ARCHITECT's control then LANDSCAPE ARCHITECT shall, on written demand to CLIENT (but without termination of this Agreement) be paid as provided in paragraph 5.3.2. If such delay or suspension extends for more than three months (for reasons beyond LANDSCAPE ARCHITECT's control) or if LANDSCAPE ARCHITECT, for any reason, is required to render services more than three months after initial date of letter of agreement, the various rates of compensation shall be subject to renegotiation.

## SECTION 5 - PAYMENTS TO LANDSCAPE ARCHITECT

5.1.1. For Basic Services. CLIENT shall pay LANDSCAPE ARCHITECT for Basic Services described in the Letter of Agreement rendered under Section 1 the Lump Sum or Time and Materials Fee as described in the Letter of Agreement.

5.1.2. For Additional Services. CLIENT shall pay LANDSCAPE ARCHITECT for Additional Services rendered under Section 2 as follows:

5.1.2.1. General. For Additional Services rendered, the fee shall be that which is agreed upon on an Authorization for Additional Services form. This Authorization for Additional Services form shall be issued at the time of CLIENT's request and shall include revised scope of work. The Authorization for Additional Services form shall be signed by the CLIENT and this will act as notice to proceed with Additional Services.

5.1.3. Reimbursable Expenses. In addition to payments provided for in paragraphs 5.1.1 and 5.1.2, CLIENT shall pay LANDSCAPE ARCHITECT the actual costs (times a factor of 1.1) of all Reimbursable Expenses incurred in connection with all Basic and Additional Services if defined in the attached Letter of Agreement.

5.1.4. The terms "Reimbursable Expenses" will have the meanings assigned in paragraph 5.4.

### 5.2. Times of Payments

5.2.1. LANDSCAPE ARCHITECT shall submit periodic invoices for Basic and Additional Services rendered and for Reimbursable Expenses incurred at significant project milestones. The invoices will be based upon LANDSCAPE ARCHITECT's estimate of the proportion of the total services actually completed at the time of billing. Payment terms are net 30 days. CLIENT shall make prompt payments in response to LANDSCAPE ARCHITECT's statements.

### 5.3. Other Provisions Concerning Payments.

5.3.1. If CLIENT fails to make any payment due LANDSCAPE ARCHITECT for services and expenses within the limits described in the attached Letter of Agreement, the amounts due LANDSCAPE ARCHITECT shall include a charge at the rate of 1.5% per month from said thirtieth day, and in addition, LANDSCAPE ARCHITECT may (after giving seven days written notice to CLIENT) suspend services under this Agreement until he has been paid in full all amounts due him for services and expenses.

5.3.2. In the event of termination by CLIENT under paragraph 7.1 of the Basic Services; LANDSCAPE ARCHITECT will be paid for services rendered up to that time (on the basis of Direct Labor Costs times a factor of 3.2) for services rendered to date of termination by principal and employees assigned to This Part of the Project. In the event of any such termination, LANDSCAPE ARCHITECT will be paid for all unpaid Additional Services and unpaid Reimbursable Expenses, plus all termination expenses. Termination Expenses mean Reimbursable Expenses directly attributable to termination, which shall include an amount computed as a percentage of total compensation for Basic Services earned by LANDSCAPE ARCHITECT to the date of termination, as follows:

20% if termination occurs after commencement of the Design Phase.

### 5.4. Definitions.

5.4.1. The Direct Labor Costs used as a basis for payment means salaries and wages (basic and incentive) paid to all personnel engaged directly on the Projects, including but not limited to; LANDSCAPE ARCHITECTs, designers, drafters, estimators, administration, and clerical.



5.4.2. Reimbursable Expenses means the actual expenses incurred (directly or indirectly) in connection with the Project for: postage, toll, reproduction of reports, Drawings, Specifications, and similar Project related items in addition to those required under Section 1; project related travel and lodging costs; and, if authorized in advance by CLIENT, overtime work requiring higher than regular rates.

## SECTION 6 - OPINIONS OF COST

### 6.1. Opinions of Cost.

Since LANDSCAPE ARCHITECT has no control over the cost of labor, material, equipment, or services furnished by others, or over the Contractor(s) methods of determining prices, or over competitive bidding or market conditions, then his opinions of probable Construction cost for This Part of the Project provided for herein are to be made on the basis of his experience and qualifications; and represent his best judgment as an experienced and qualified Professional LANDSCAPE ARCHITECT (familiar with the construction industry). LANDSCAPE ARCHITECT cannot and does not guarantee that proposals, bids, or actual Construction Cost for This Part of the Project will not vary from opinions of probable cost prepared by him.

## SECTION 7 - GENERAL CONSIDERATIONS

### 7.1. Termination.

7.1.1. The obligation to provide further services under this Agreement may be terminated by either party upon seven days written notice.

### 7.2. Reuse of Documents.

7.2.1. All documents including Drawings and Specifications prepared by LANDSCAPE ARCHITECT pursuant to this Agreement are instruments of service in respect of the Project. They are not intended or represented to be suitable for reuse by CLIENT or others on extensions of the Project or on any other project. Any reuse, without written verification or adaptation by LANDSCAPE ARCHITECT for the specific purpose intended, will be at CLIENT's sole risk and without liability or legal exposure to LANDSCAPE ARCHITECT. CLIENT shall indemnify and hold harmless LANDSCAPE ARCHITECT from all claims, damages, losses, and expenses (including attorney's fees) arising out of or resulting therefrom. Any such verification or adaptation will entitle LANDSCAPE ARCHITECT to further compensation at rates to be agreed upon by CLIENT and LANDSCAPE ARCHITECT.

### 7.3. Records.

7.3.1. Records of LANDSCAPE ARCHITECT's Direct Labor Costs, Payroll Costs, and Reimbursable Expenses (pertaining to This Part of the Project) will be kept on a generally recognized accounting basis and made available to CLIENT on request.

7.3.2. LANDSCAPE ARCHITECT shall maintain all design calculations on file in legible form. A copy of these shall be available to CLIENT at LANDSCAPE ARCHITECT's expense; and the originals shall not be disposed of by LANDSCAPE ARCHITECT until after sixty days prior written notice to CLIENT or 60 months after project completion without notice.

7.3.3. LANDSCAPE ARCHITECT's records and design calculations will be available for examination and audit as required in writing by CLIENT.

### 7.4. Insurance.

7.4.1. CLIENT and LANDSCAPE ARCHITECT shall each procure and maintain insurance (other than life insurance) for protection from claims under worker's compensation acts, claims for damages because of bodily injury (including personal injury), sickness or disease or death of any and all employees or of any person other than such employees, and from claims or damages because of injury to or destruction of property including loss of use resulting therefrom.

7.4.2. Also CLIENT and LANDSCAPE ARCHITECT shall each procure and maintain professional liability insurance for protection from claims arising out of performance of professional services caused by any negligent error, omission, or act for which the insured is legally liable. Such professional liability insurance will provide for coverage in such amounts, with

such deductible provisions, and for such periods of time as appropriate for the size of the project; and certificates indicating that such insurance is in effect will be exchanged by them.

7.4.3. CLIENT will also cause other professional consultants retained by CLIENT for the Project to procure and maintain comparable professional liability insurance coverage.

7.4.4. CLIENT agrees to limit the LANDSCAPE ARCHITECT's liability to the CLIENT and to all construction contractors and subcontractors on the project, due to the LANDSCAPE ARCHITECT's negligent acts, errors or omissions, or any claim of any nature whatsoever arising out of or relating to the performance of professional services under this agreement, such that the total aggregate liability of the LANDSCAPE ARCHITECT to all those named shall not exceed \$50,000 or the LANDSCAPE ARCHITECT's total fee for services rendered on this project, whichever is less.

7.5. Controlling Law.

7.5.1. This Agreement is to be governed by the law of the State of Kansas.

7.6. Successors and Assigns.

7.6.1. CLIENT and LANDSCAPE ARCHITECT each binds himself and his partners, successors, executors, administrators, assigns and legal representatives to the other party to this Agreement and to the partners, successors, executors, administrators, assigns and legal representatives of such other party, in respect to all covenants, agreements and obligations of this Agreement.

7.6.2. Neither CLIENT nor LANDSCAPE ARCHITECT shall assign, sublet, nor transfer any rights under or interest in (including, but without limitation, moneys that may become due or moneys that are due) this Agreement without the written consent of the other, except as stated in paragraph 7.4.1. and except to the extent that the effect of this limitation may be restricted by law. Unless specifically stated to the contrary in any written consent to an assignment, no assignment will release or discharge the assignor from any duty or responsibility under this Agreement. Nothing contained in this paragraph shall prevent LANDSCAPE ARCHITECT from employing such independent consultants, associates, and subcontractors as he may deem appropriate to assist him in the performance of services hereunder.

7.6.3. Nothing herein shall be construed to give any rights or benefits hereunder to anyone other than CLIENT and LANDSCAPE ARCHITECT.

Proposed and Accepted by:

Landworks Studio, LLC

Carisa McMullen | Principal

X

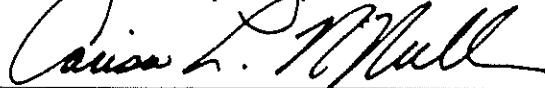

City of Paola, KS

X

Date



# Proposed Scope and Fee

## Family Pool - Paola, KS

prepared on 11/16/22 by:  
Carisa - Principal

### Phase 1 - Program Verification and Concept Development \$16,720

- Task 1 Introductory Meeting and Site Visit
- Task 2 Kick-Off/Prioritization Meeting
- Task 3 Identify Preliminary Water Activities and Features
- Task 4 Develop Aquatic Program and Capacities
- Task 5 Develop Cost Estimates for Planning

### Phase 2 - Schematic Design \$35,290

- Task 1 Develop SD Aquatic Drawings
- Task 2 Develop Architectural Drawings
- Task 3 Develop SD Site Plan Options
- Task 4 Develop Cost Estimates
- Task 5 Topographic Survey

### Phase 3 - Design Development \$55,330

- Task 1 Refine DD Level Aquatic Drawings
- Task 2 Define Pool Specialty and Mechanical Equipment
- Task 3 Update Utility Requirements for new features
- Task 4 Refine DD Level Architectural Plans
- Task 5 Refine DD Site Plans
- Task 6 Draft Specifications
- Task 7 Verify Code Compliance
- Task 8 Refine Cost Estimates

### Phase 4 - Construction Documents \$64,280

- Task 1 Finalize Final Aquatic Drawings
- Task 2 Finalize Pool Mechanical Equipment Schedules
- Task 3 Finalize Architectural Plans
- Task 4 Finalize Site Plans
- Task 5 Coordinate w/ all Disciplines
- Task 6 Finalize Specifications
- Task 7 Finalize Cost Estimates
- Task 8 Address Permitting Agency Questions
- Task 9 Finalize Utility Requirements
- Task 10 Assist w/ Swimming Pool Permit Applications.

# Proposed Scope and Fee

**Phase 5 - Bidding & Negotiation** **\$2,560**

- Task 1 Respond to RFI's
- Task 2 Prepare Addenda, if necessary
- Task 3 Assist w/ Contractor Selection

**Phase 6 - Construction Administration** **\$17,350**

- Task 1 Submittal Review
- Task 2 Review Change Order Requests
- Task 3 Coordination w/ Permitting Agencies
- Task 4 Review Pool Contractor O&M Manual
- Task 5 Conduct Site Observations
- Task 6 Provide Field Reports
- Task 7 Provide Punch List
- Task 8 Complete Final Inspection

**Phase 7 - Reimbursable Expenses** **\$4,500**

- Task 1 Expenses

**Phase 8 - Geotechnical Investigation and Reporting** **\$5,920**

- Task 1 Three Borings (2 for Water Slide and 1 for Shade Structure)

**\*Special Provisions or Notes**  
*See page 2 for Additional Services options.*

TOTAL PROJECT HOURS	471 Hrs
<b>TOTAL SERVICES AND DESIGN FEE TO BILL</b>	<b>\$ 201,950</b>
+ REIMBURSABLE EXPENSES	\$ 0
<small>(reimbursable expenses are on a "Not to Exceed" basis and will only be billed as needed)</small>	
<b>Maximum Invoice Amount</b>	<b>\$ 201,950</b>

# Proposed Scope and Fee

## Family Pool - Paola (Add Services)

prepared on 11/9/22 by:  
Carisa - Principal

ADD SERVICE	ADDITIONAL DESCRIPTION	EST. PRICE
Task 1	WTI Additional Site Visits (each)	\$0.00
Task 1	Completion of Record Drawings Upon Construction Completion	\$0.00
Task 1	Field Reports and Equipment Acceptance	\$0
Task 1	Design of Power Distribution from transformers to main building	\$0
Task 2	Preliminary grounding for pool reinforcing, as required	\$0
Task 1	Borings for Slide and Shelter	\$0

### \*Special Provisions or Notes

If you had notes or provisions they would go here and as you type they will continue to expand

TOTAL PROJECT HOURS 0 Hrs

**TOTAL SERVICES AND DESIGN FEE TO BILL \$ 0**

+ REIMBURSABLE EXPENSES \$ 0

(reimbursable expenses are on a "Not to Exceed" basis and will only be billed as needed)

**Maximum Invoice Amount \$ 0**





---

**SUBJECT: Hedge Ln & Baptiste Dr Traffic Light Cabinet**  
**CONTACT: Stephanie Marler, City Clerk**  
**Kirk Rees, Public Works Director**  
**DATE: December 13, 2022**

---

**Background**

The northbound and southbound traffic signal at Hedge Ln. & Baptiste Dr. was adjusted to show a dedicated left turn arrow. Cars were unable to get through the intersection with just a flashing yellow arrow and traffic would back up during school hours.

**Issue**

When this adjustment was made it was discovered that the cabinet containing the controls needed an upgrade. Although the dedicated left turn arrow helped with traffic flow, it is extremely short and with the current signal heads there is no option for a left turn unless the arrow is green.

Director Rees received two quotes to upgrade the traffic signals at the intersection:

J. Warren Company Inc.	\$39,744.00
Capital Electric	\$43,635.00

Both quotes include the removal of existing cameras (4) and signal heads (2), installation of Miovision video detection system, controller cabinet switch out and install 4 head signal heads.

**Summary**

With the increased traffic and more to come with the Paola Crossings district, the upgrade to the signals will be very beneficial.



**Financial Impact (or Fiscal Note)**

The Street CIP fund 90.305 will be used to pay for the improvements.

**Recommendations**

I recommend approval of the quote from J. Warren Company Inc. for improvements in the amount of \$39,744.00.

**Attachments**

Quotes:

J. Warren Company  
Capital Electric



Quotation  
November 16, 2022

Baptiste and Hedge Lane Modifications  
City of Paola, KS

Kirk,

We are pleased to submit our proposal for the change to the traffic signal at Hedge Lane & Baptiste. Material is to be provided by the city.

Supply & Install (2) 4 Section Signal Heads. - \$ 5,321.00

Install Miovision Detection - \$ 21,332.00

Change out cabinet - \$ 12,841.00

Remove unused cameras and signal heads - \$ 250.00

Total - \$ 39,744.00

Price for cabinet change out does not include traffic control while the signal is down.

Thank you for considering our proposal.

Sincerely,

A handwritten signature in black ink that reads "Adam B. Warren". The signature is written in a cursive style with a large, prominent "A" and "W".

Adam B. Warren  
J. Warren Co. Inc.

11/9/2022

**Project:** Signal Upgrades, Hedge Lane and Baptiste Drive

**City / County / State:** Paola, Johnson County, Kansas

We are pleased to present the quote of \$ **43,365.00** for the above-mentioned project.

**Conditions:**

- Price based on Capital Electric being provided reasonable time, access and notification to install the traffic signal improvements.
- Our proposal is based on our entering into a contract in a form mutually satisfactory to both parties.
- **Quote is valid for 30 days. After 30 days, we shall have the right to re-quote. It is imperative that we be notified as soon as possible after the award of the project of your intent to award us the work. Extreme volatility in material pricing requires that we secure material orders as soon as possible, so we can hold our pricing.**
- Payments terms: Net 30 -- Retention: 0%.
- Quote is based on the attached scope of work.

**Exclusions:**

- Performance, Maintenance and/or Payment Bond. If required, please add **0.75%** to our quote.
- Tax

**Special:**

- Capital Electric Line Builders will do everything we can to honor our pricing and to meet all the completion dates for the projects we currently have under contract or are currently quoting, but unfortunately the traffic signal, street lighting, and intelligent transportation systems material manufacturers are facing unprecedented shortages in acquiring the raw materials and equipment they need this year. This has caused our suppliers to miss shipping deadlines or become unable to fulfill our current orders, and they are declaring force majeure with most of their clients. So, in good faith, we will continue to honor our obligations with our customers but under no circumstance will Capital Electric Line Builders be responsible for any liquidated damages or any other form of restitution resulting from this industry wide shortage of traffic signal, lighting, or intelligent transportation systems components. We will endeavor to find other practical solutions for and with our clients to find an equitable solution for this nation-wide shortage.



If you have any questions, please call me at (816) 283-6843.

Respectfully Submitted,

---

**David Haggard**

Project Manager / Estimator

[david.haggard@capitalelectric.com](mailto:david.haggard@capitalelectric.com)

SCHEDULE OF ITEMS

DATE: 11/9/2022  
 REVISED:

CONTRACT ID:

PROJECT (S): Hedge Lane and Baptist Drive Signal Upgrades

ITEM DESCRIPTION		Unit	Quantity	Unit Price	Bid Amount
1	Remove existing cameras(4) and signal heads(2)	LS	1	\$ 3,670.00	\$ 3,670.00
3	Install Miovision video detection system	LS	1	\$20,415.00	\$ 20,415.00
4	Controller cabinet switch out	EA	1	\$14,500.00	\$ 14,500.00
5	Install 4 head signal heads	EA	2	\$ 2,525.00	\$ 5,050.00
<b>SECTION TOTAL</b>					

CAPITAL ELECTRIC LINE BUILDERS TOTAL BID

\$ 43,635.00

	Capital Electric	J Warren Company
Remove existing cameras (4) and signal heads (2)	\$3,670.00	\$250.00
Install Miovision video detection system	\$20,415.00	\$21,332.00
Controller cabinet switch out	\$14,500.00	\$12,841.00
Install 4 head signal heads	\$5,050.00	\$5,321.00
Total	\$43,635.00	\$39,744.00



---

**SUBJECT:** Fire Engine Purchase Approval  
**CONTACT:** Randi Shannon, City Manager  
Andy Martin, Fire Chief  
**DATE:** December 13, 2022

---

**Background**

Engine #3 was scheduled to be replaced in 2024, at the end of the standard 15 year replacement cycle. Due to the extended lead times of a new engine, coupled with the fact that the resale value of our current Engine #3 will drop exponentially after the 15 year mark, Chief Martin and staff thought it was prudent to push the purchase of a new engine up to the end of 2022.

**Summary**

Chief Martin worked with three manufacturers to develop specifications for the new engine. All three manufacturers offered almost identical units, as well as offering Brindlee Mountain as a trade-in company with an estimated \$80,000 for our current Engine #3. Summary of the three bids that were reviewed at the City Council Work Study are outlined below.

**Pierce Mfg Appleton Wisconsin est. 1913**

Dealer: Conrad Fire Equipment, Olathe, KS.

Engine Name: Arrow XT #1125

Lead time: 36 months

Cost: **\$678,641.08** with 100% prepay

**Sparton ER Brandon SD est. 2003.**

Dealer: Feld Fire, Grain Valley, MO.

Engine Name: Spartan Metro Star

Lead time: 24 months

Cost: **\$664,579.00** with 100% prepay



**Sutphen Crop. Amlin OH est. 1892**

Dealer: Flint Hills Fire, Saline, KS.

Engine Name: Monarch S1

Lead time: 24 months

Cost: **\$606,537.85** with 100% prepay

**Discussion**

Staff recommendation would be to purchase the Sutphen Monarch S1 suing the 100% prepay option for \$606,537.85 this year, and sell the current Engine #3 outright on delivery with the net cost estimate of \$516,538 to \$456,538 depending on the sales price of Engine #3.

**Financial Impact (or Fiscal Note)**

The City would choose the 100% prepay amount option, utilizing the ¼ cent sales tax that was approved for Fire operations, maintenance, equipment and facilities.

**Recommendations**

I recommend the approval of purchasing the Sutphen Monarch S1, from the Sutphen Corporation in the amount of \$606,537.85.

**Attachments**

Bids:

1. Sutphen Corporation
2. Conrad Fire Equipment
3. Feld Fire



**\$606,538**

**PREPAY**



**FAMILY OWNED  
SINCE 1890**

**Prepayment Discount Options  
For The  
Miami County Fire Department #1  
Paola, KS  
10/14/2022**

**Current Bid Price                   \$632,359.18**

Option 1 25%	For a prepayment in the amount of       \$158,089.80 would be   \$6,455.33   for a total selling price of . . . .	the discount \$625,903.85
Option 2 50%	For a prepayment in the amount of       \$316,179.59 would be   \$12,910.67   for a total selling price of . . . .	the discount \$619,448.51
Option 3 75%	For a prepayment in the amount of       \$474,269.39 would be   \$19,366.00   for a total selling price of . . . .	the discount \$612,993.18
Option 4 100%	For a full prepayment, we offer a discount of   \$25,821.33 for a final selling price of . . . . .	\$606,537.85

**NOTE:** For any option above, the prepayment would be due within 30 days of contract signing in order to receive the discounts listed. Any remaining balance would be due at the time of delivery.

**Sutphen Corporation**  
PO Box 158 • Amlin, OH 43002-0158  
6450 Eiterman Road • Dublin, OH 43016-8711  
Tel 614 889-1005 • Toll Free 800 848-5860 • Fax 614 889-0874  
[www.sutphen.com](http://www.sutphen.com) • [Sutphen@sutphen.com](mailto:Sutphen@sutphen.com)

**\$678,641 PRE PAY**



**Apparatus Proposal**

Customer Name: **PAOLA, KS**

Sales Rep: **ROGER BROWN**

Submitted Date: **11/2/22**

Expiration Date: **1/2/23**

**Apparatus Detail**

Qty.	Description	Price
<b>1</b>	<b>PIERCE ARROW XT PUMPER</b>	<b>\$ 720,711.47</b>

Proposal Bid No.: **1125**

Proposal Doc Date: **1/2/23**

Performance Bond: **NO**

Warranty Period: **Standard**

Estimated Build Time: **36 MO**

**Payment Options**

**OPTION 1 (with Pre-Payment Discount)**

Apparatus Purchase Price	\$ 720,711.47
Trade-in Value	-\$ 80,000.00
Price After Trade-in	\$ 640,711.47
Pre-Payment Discount	-\$ 42,070.39
Extrication Rescue Tools	\$ 0.00
Loose Equipment	\$ 0.00
Options	\$ 0.00
Due Upon Order	\$ 598,641.08

**OPTION 2 (w/o Pre-Payment Discount)**

Apparatus Purchase Price	\$ 720,711.47
Trade-in Value	-\$ 80,000.00
Price After Trade-in	\$ 640,711.47
Pre-Payment Discount	N/A
Extrication Rescue Tools*	\$ 0.00
Loose Equipment*	\$ 0.00
Options	\$ 0.00
Due Upon Delivery	\$ 640,711.47

**Payment Terms**

OPTION 1 PRICING IS BASED ON FULL PAYMENT BEING MADE AT TIME OF ORDER.  
 OPTION 2 PRICING IS BASED ON FULL PAYMENT BEING MADE AT TIME OF PRODUCT DELIVERY. \*RESCUE TOOLS AND LOOSE EQUIPMENT THAT ARE NOT PRE-PAID MUST BE PAID FOR UPON DELIVERY; TO SECURE THE QUOTED PRICING, TOOLS AND EQUIPMENT WILL BE PROCESSED IMMEDIATELY UPON ORDER PLACEMENT AND PAYMENT FOR TOOLS AND EQUIPMENT WILL BE DUE UPON DELIVERY, WHICH WILL BE PRIOR TO APPARATUS DELIVERY.\*

**Notes**

ABOVE REFERENCED \$80,000.00 TRADE-IN VALUE IS BASED ON ATTACHED THIRD PARTY VALUATION AND IS SUBJECT TO CHANGE AT TIME OF DELIVERY. CUSTOMER MUST MEET ALL SPECIFIED REQUIREMENTS IN ATTACHED THIRD PARTY TRADE AGREEMENT TO RECEIVE FULL CREDIT FOR THE UNIT.

NOTE: Pre-payment discounts are based on purchase price at time of order. Manufacturing build time is subject to change up to the time an order is placed. If deferred payment arrangements are required, the Customer must make such financial arrangements through a financial institution acceptable to Company. All taxes, excises and levies that Company may be required to pay or collect by reason of any present or future law or by any governmental authority based upon the sale, purchase, delivery, storage, processing, use, consumption, or transportation of the Product sold by Company to the Customer shall be for the account of the Customer and shall be added to the Purchase Price. All delivery prices or prices with freight allowance are based upon prevailing freight rates and, in the event of any increase or decrease in such rates, the prices on all unshipped Product will be increased or decreased accordingly. Delinquent payments shall be subject to a carrying charge of 1.5 percent per month or such lesser amount permitted by law. Company will not be required to accept payment other than as set forth in this Agreement. Company shall have and retain a purchase money security interest in all goods and products now or hereafter sold to the Customer by Company or any of its affiliated companies to secure payment of the Purchase Price for all such goods and products. In the event of nonpayment by the Customer of any debt, obligation or liability now or hereafter incurred or owing by the Customer to Company, Company shall have and may exercise all rights and remedies of a secured party under Article 9 of the Uniform Commercial Code (UCC) as adopted by the state of [KANSAS].

**\$ 664,579 PREPAY**



**Proposal for a Spartan Metro Star Custom Pumper**

This proposal has been prepared for:

**City of Paola, Kansas**

We hereby propose to furnish to you, subject to proper execution of a signed contract by you and an officer of Ed M Feld Equipment Co Inc, dba Feld Fire, the following Pumper to be built in accordance with the attached Spartan Metro Star Pumper Specifications.

- Upon completion of contract, (1) one Spartan Metro Star Pumper as specified by customer, a dealer provided and attached Akron 3426 Apollo Single Waterway Monitor, and a 1", 10-30 gpm nozzle, for **Six Hundred Eighty-Five Thousand Three Hundred Ninety-Eight Dollars and zero cents (\$685,398.00)**.
- Price includes Spartan's standard, single source 2-year bumper-to-bumper warranty serviced by Feld Fire mobile technicians.
- Delivery of the apparatus shall be delivered to the department 440 days from signature of pre-conference changes, after zoom meeting between factory engineers, dealer representative, and the department.
- Price Proposal is valid until December 1<sup>st</sup>, 2022.
- Prepayment options are available:
  - o 100% Prepay would give you an additional savings of \$20,819
  - o 50% Prepay would give you an additional savings of \$10,410
- **Total 100% Prepaid price is \$664,579**
- **This price does not include trade-in, there is a trade-in offer from Brindlee Mountain Apparatus included in bid book. Upon release of the 2009 Sutphen Custom Pumper on or before 5/31/24 with their terms, Brindlee will allocate \$80,000 in funds to the department, terms are attached.**

We appreciate the opportunity to work with you on the purchase of a new pumper,

Sincerely,

*A division of* **ED M. FELD EQUIPMENT CO., INC.**

113 North Griffith Road · Carroll, Iowa 51401 · T 800 568 2403 · F 712 792 6658 · [www.feldfire.com](http://www.feldfire.com)  
1330 NW Jefferson St., Grain Valley, MO 64029 T 816-443-2738 F 816-443-2864  
10403 Baur Blvd St E., Olivette, MO 63132

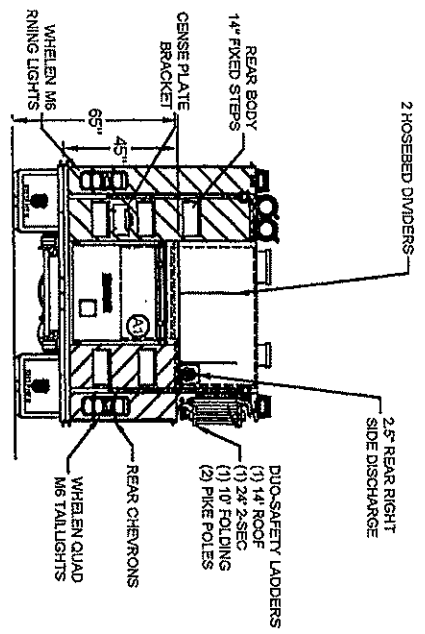

LEFT SIDE COMPARTMENTS			RIGHT SIDE COMPARTMENTS			
COMP'T	DOORS	OPENING DIMENSIONS	INSIDE DIMENSIONS	VOLUME	INSIDE DIMENSIONS	VOLUME
L1	ROLL-UP	26.5W X 63.4H	31.1W X 57.0H X 27.2D	84.0 CU. FT.		
L2	ROLL-UP	31.5W X 56.4H	37.0W X 47.5H X 27.2D	41.0 CU. FT.		
L3	ROLL-UP	31.5W X 63.4H	37.0W X 57.0H X 27.2D	80.0 CU. FT.		
REAR STEP COMPARTMENT			INSIDE DIMENSIONS	VOLUME		
R1	ROLL-UP	26.5W X 31.4H	31.1W X 40.1H X 27.2D	78.0 CU. FT.		
R2	DRUP DOWN	31.0W X 21.5H	39.0W X 18.0H X 28.5D	82.0 CU. FT.		
R3	ROLL-UP	31.5W X 31.4H	37.0W X 47.5H X 27.2D	48.0 CU. FT.		
REAR STEP COMPARTMENT			INSIDE DIMENSIONS	VOLUME		
AI	ROLL-UP	31.5W X 32.5H	40.0W X 40.0H X 31.0D	20.0 CU. FT.		
TOTAL			251.0 CU. FT.			

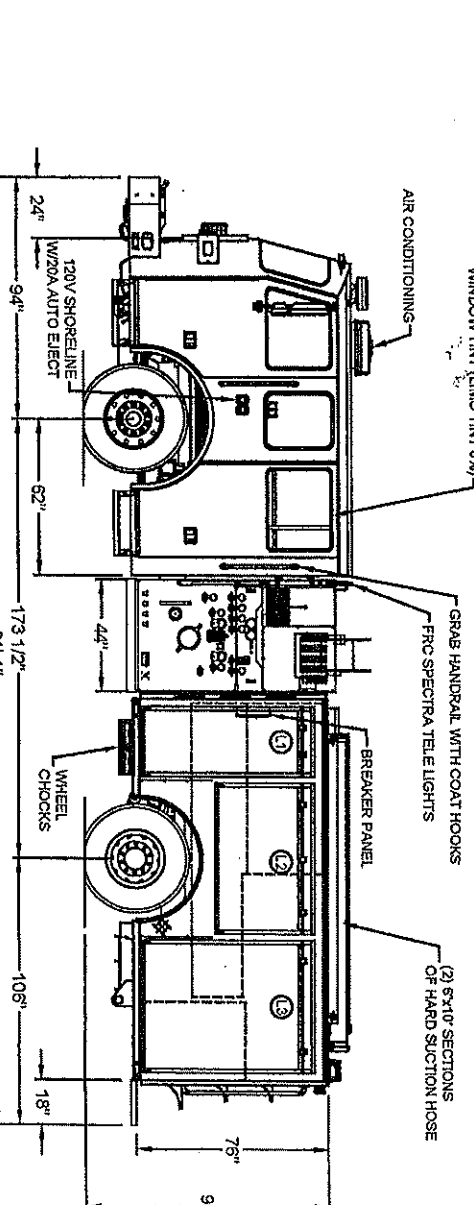
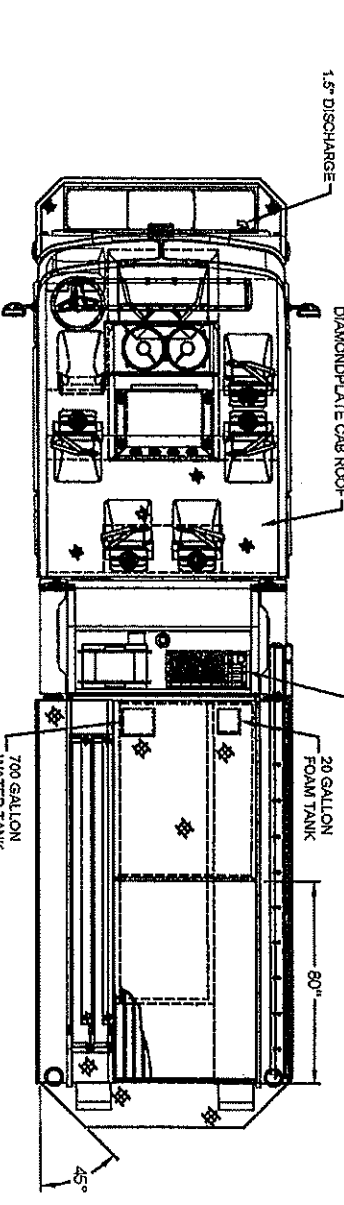
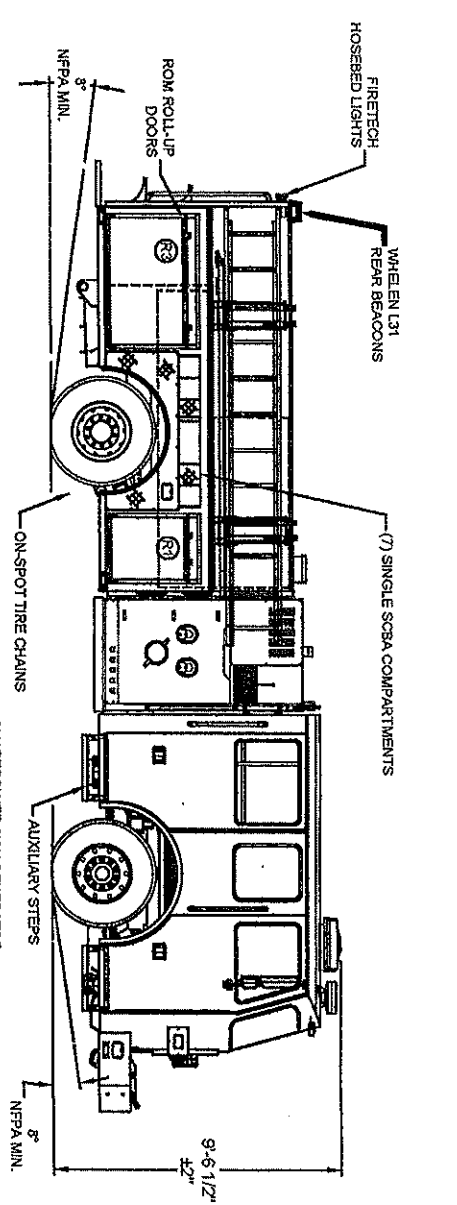
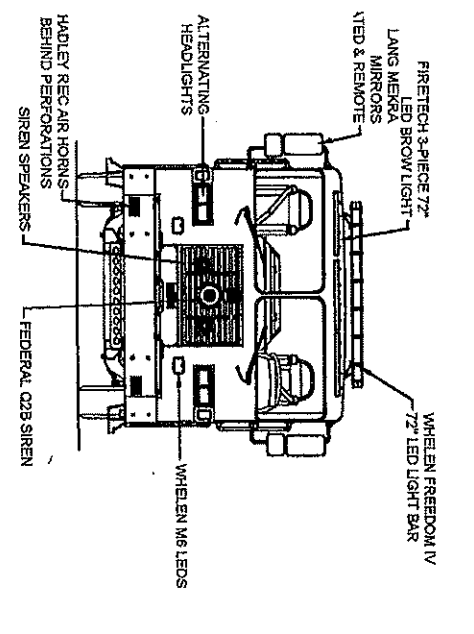

DIMENSIONS SHOWN ON THIS DRAWING ARE APPROXIMATE AND ARE SUBJECT TO MINOR DEVIATIONS DURING CONSTRUCTION. THE EVENT OF A DISCREPANCY BETWEEN THE DIMENSIONS AND DRAWINGS, THE SUPPLIER'S SPECIFICATIONS SHALL PREVAIL. DRAWINGS FOR REFERENCE ONLY. SOME ITEMS PRICED AS MAY NOT BE SHOWN OR NOTED.

**CUSTOMER APPROVAL**

NAME: \_\_\_\_\_ TITLE: \_\_\_\_\_ DATE: \_\_\_\_\_

DESCRIPTION: \_\_\_\_\_ BY: \_\_\_\_\_ DATE: \_\_\_\_\_

DATE: 10/14/2022  
 DRAWN BY: KEDEL  
 REVIEWER: DAVALOR  
 APPROVER: JABVEL

MICO FIRE DEPARTMENT #1  
 PAOLA, KS  
 CUSTOMER NUMBER: ST BODY  
 2301A (KS 2022 S1)

**From:** jschreiber@firetruckmall.com  
**Sent:** Saturday, October 29, 2022 12:50 PM  
**To:** Spencer Stephens  
**Subject:** Purchase Quote from Brindlee Mountain Fire Apparatus



Reference: 2009 Sutphen Custom Pumper from Paola FD - KS (the "Apparatus")  
Date Quoted: 10/28/2022

Spencer Stephens,

Thank you for allowing Brindlee Mountain Fire Apparatus, LLC ("BMFA") the opportunity to provide an offer to purchase the Apparatus. We are pleased to offer Feld Fire ("Seller") \$80,000 for the purchase of the Apparatus, subject to the terms and conditions set forth herein.

The offer is valid for acceptance by Seller until 12/31/2022. **Seller must communicate acceptance of this offer to BMFA via email or otherwise in writing on or before 12/31/2022.** If Seller accepts this offer on or before the date set forth above, this offer becomes a contract of purchase and sale of the Apparatus.

Seller shall release the Apparatus to BMFA on or before 5/31/2024. All ground ladders, discharge caps, intake plugs, generators (permanently mounted and portable), cascade systems and cascade bottles, and permanently mounted items such as light towers, shall remain with the Apparatus and shall be released to BMFA.; The apparatus tires shall not be older than 7 years, and shall have a minimum tread depth of 4/32 on steering axles, 2/32 on non-steering axles, and no punctures, cuts to the cord, bulges or sidewall separation.

BMFA shall pay Seller the full purchase price via Check or Wire Transfer at the time of or prior to the release of the Apparatus.

Seller shall provide a pump test certificate for the Apparatus dated within 30 days prior to the release date with results satisfactory to BMFA, including proper operation of the pressure governor, relief valve, primer, and foam system if applicable.

Seller represents and warrants that the description, condition, and specifications of the Apparatus provided to BMFA are true and correct. Any Apparatus with a light tower must be fully functional unless other provisions are agreed upon with BMFA.

Seller represents and warrants that all prior damage of any type (including but not limited to collision, fire, and flood) has been disclosed to BMFA prior to Seller's acceptance of this offer. Seller shall immediately disclose to BMFA any damage to the

Apparatus occurring after Seller's acceptance of this offer. In the event of such damage, at BMFA's option the purchase price of the Apparatus shall be adjusted downward to account for such damage and Seller and BMFA shall negotiate in good faith to determine the amount of such purchase price adjustment.

Prior to payment of the purchase price by BMFA, Seller shall provide BMFA with a copy of the title (or in the circumstance set forth below the manufacturer's statement of origin or certificate of origin ("MSO or MCO") of the Apparatus reflecting the Seller as the owner of the Apparatus. Seller represents and warrants that the Apparatus will be sold to BMFA free and clear of any liens or other encumbrances. Seller shall deliver the vehicle title for the Apparatus, free of all liens, to BMFA within ten (10) days after final payment by BMFA. An MSO or MCO is acceptable only from original vehicle manufacturer and is not considered as proof of ownership from the Seller except when the state in which the purchaser is located does not require registration or title on emergency vehicles and a copy of that state's current law or statute clearly stating the exemption is provided by Seller with the MSO or MCO.

The apparatus must be completely drained of water prior to shipment or being stored outside prior to shipment. To effectively drain the truck of water, remove all caps and plugs (store on the truck in a compartment), open all intake/discharge valves halfway, and open all drain valves to include the pump cooler and auxiliary cooler. Failure to drain all water from the truck prior to shipment could result in damage to the fire apparatus and corresponding repairs will be performed at the expense of the seller.

BMFA's obligation to purchase the Apparatus is contingent upon Seller's representations and warranties hereunder being true and correct and Seller's performance of its obligations hereunder. In the event Seller's representations and warranties hereunder are not true and correct or Seller does not perform its obligations hereunder, at BMFA's option the purchase price of the Apparatus shall be adjusted downward to account for such matters and Seller and BMFA shall negotiate in good faith to determine the amount of such purchase price adjustment. BMFA's remedies set forth herein are in addition to any and all other rights and remedies that may be available to BMFA at law, at equity or otherwise.

This offer shall be governed by, construed, and enforced in accordance with the laws of Alabama. The undersigned by execution and delivery of this Agreement do hereby submit to the exclusive jurisdiction and venue of the state and federal courts of Marshall County, Alabama.



---

**SUBJECT: Miami County Restricted Parking Request**  
**CONTACT: Stephanie Marler, City Clerk**  
**DATE: December 13, 2022**

---

**Background**

Miami County is working to facilitate an additional district court judge. The short term plan is to use the commission chamber within the Administration Building each Monday, Tuesday, Thursday and Friday.

**Issue**

Below is the emailed request from Miami County:

*MICO is working through logistical issues to facilitate an additional district court judge. In the short term, the commission chamber within the Administration Building will be utilized as a courtroom each Monday, Tuesday, Thursday, and Friday on a weekly basis. Attached is an aerial view of the Pearl Street and Mission Street intersection. I ask that the City of Paola allow for a reserved or dedicated parking spot along Pearl Street as depicted in the aerial view's red circle. By allowing for this parking spot, Sheriff Office transport staff will be able to directly load/unload inmates a few feet away from the door that accesses the improvised courtroom. The commission chamber has two doors that allow egress to the outside of the building. In this instance, the southwest door will be utilized. Otherwise, transport staff will be required to bring restrained inmates through the primary first floor entrance and hallway utilized by the general public registering vehicles, registering to vote, etc.*

*I realize this is not a normal request. I envision the commission chamber being used as a courtroom for three years until other accommodations can be incorporated to properly hold district court proceedings. I am happy to meet with you onsite to answer questions or provide more detail concerning this request.*

*Sincerely, Shane Krull - County Administrator*

**Summary**

A resolution to amend the Traffic Control Device Schedule allowing restricted parking in 1 spot is being considered.

I also noticed the restricted parking for the Bed and Breakfast previously at 105 E Wea is included in the schedule. I suggest removing this with the resolution.

**Recommendations**

I recommend approving Resolution 2022-011 amending the Traffic Control Device Schedule.

**Attachments**

Aerial view of Pearl Street & Mission Street intersection  
Proposed Resolution 2022-011





Overview

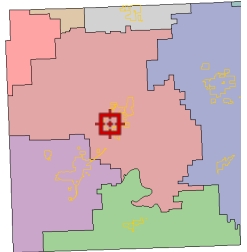

Legend

- City Limits
- Centerlines
- Parcels
- Lakes

Date created: 11/22/2022  
Last Data Uploaded: 11/22/2022 12:22:45 PM

Developed by Schneider  
GEOSPATIAL

**RESOLUTION 2022-011**

**A RESOLUTION AMENDING THE OFFICIAL TRAFFIC CONTROL DEVICE SCHEDULES FOR THE CITY OF PAOLA, KANSAS.**

**WHEREAS**, pursuant to KSA 8-2005 and Section 14-104 of the Municipal Code of the City of Paola, 2021, the Governing Body of the City of Paola, Kansas, desires to amend the Official Traffic Control Device Schedules, and

**WHEREAS**, the request for restricted parking for Miami County court proceedings should be reevaluated in January 2026 to determine if the parking restriction should continue, and

**WHEREAS**, the removal of the restricted parking on Wea Street is due to the Bed and Breakfast no longer operating at that location.

**NOW, THEREFORE, BE IT RESOLVED BY THE CITY COUNCIL OF THE CITY OF PAOLA, KANSAS AS FOLLOWS:**

**Section 1:** Schedule F – Parking Restrictions of The Official Traffic Control Device Schedules for the City of Paola, Kansas shall be amended to **ADD** the following:

**Business Parking Only**

**Street / Intersection**

Pearl Street

**Direction**

The southern most parking space on the east side of Pearl St. in front of the Miami County Administration Building is restricted for Miami County Inmate Transport Staff only on Monday, Tuesday, Thursday and Friday during court hours.

**Section 2:** Schedule F – Parking Restrictions of The Official Traffic Control Device Schedules for the City of Paola, Kansas shall be amended to **REMOVE** the following:

**Business Parking Only**

**Street / Intersection**

Wea Street

**Direction**

Directly in front of the business located at 105 E Wea Street. This restriction shall be valid only so long as this property is actively and legally operating as a Bed and Breakfast under a valid Conditional Use Permit.

**Section 3:** This resolution shall be effective upon approval.

**PASSED, APPROVED AND ADOPTED** this 13th day of December, 2022.

---

Leigh House, Mayor

ATTEST: [seal]

---

Stephanie Marler, City Clerk



**Paola City Council  
Memorandum**

**Agenda Item 13**

***EXECUTIVE SESSION: LAND ACQUISITION***

Suggested Motion:

*I move city council recess into Executive Session for the preliminary discussion of the acquisition of real property, pursuant to exception, K.S.A. 75-4319(b)(6). The meeting shall include the Mayor and Council, City Manager, and City Clerk,. The regular meeting shall reconvene in the Municipal Court Room at [state actual time].*